

2019 S5 RETAILER ASSEMBLY MANUAL

cervélo

velo

TABLE OF CONTENTS

Important Information.....	1	Fork Installation.....	20
List of Tools & Supplies.....	2	Fork Topper Installation.....	21
2019 S5 Parts List.....	3	Stem Installation.....	22
Frame Features.....	4	Stack Adjustment.....	23
Handlebar & Stem Components.....	5	Stem Fixing Screw Guide.....	24
Handlebar Components - Stack.....	6	Handlebar Installation.....	25
Handlebar Components - Pitch Adjust.....	7	Handlebar & Stem - Electric Cable Routing -	26
Fork & Headset Components.....	8	Handlebar & Stem - Mechanical Cable Routing.....	27
Small Parts.....	9	Di2 Battery Installation.....	28
Frame Preparation.....	10	Electric Cable Installation.....	29
S5 Assembly Overview.....	11	Mechanical Cable Installation.....	30
Before You Build.....	13	Seatpost Assembly.....	31
Electric Cable Preparation.....	14	Seatpost Cutting Instructions.....	30
Mechanical Cable Preparation.....	15	Frame Protection Installation.....	33
Brake Housing Routing.....	16	Tire Clearance.....	34
Electric Cable Routing.....	18	Rapid Axle Wheel Installation.....	35
Mechanical Cable Routing.....	19		

IMPORTANT INFORMATION

This manual is intended to assist Cervélo retailers in setting up and customizing the 2019 S5 bicycle. This manual is not intended for consumer use, and requires the use of the specified tools to ensure proper assembly. This manual also references proprietary parts available only to retailers through direct ordering from Cervélo.

Failure to use the specified parts and to follow the supplied assembly instructions may result in a loss of control while riding and serious injury. This manual is an overview of the steps required to assemble this bicycle and to make any desired modifications as set forth in this manual. This manual assumes that the retailer has the minimum required background and skill level required of all professional bicycle mechanics. See <https://www.probma.org/>

NOTE: Cervélo strongly recommends that all assembly and adjustment procedures be performed by an authorized Cervélo retailer. If you are a Cervélo S5 consumer/purchaser reading this manual we suggest that before attempting to undertake any of the procedures in this manual that you consult your authorized Cervélo retailer, or visit us at www.cervelo.com/support







LIST OF TOOLS & SUPPLIES

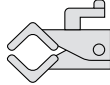
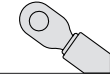

This manual outlines a number of procedures for making optional adjustments to the S5 which differ from the way the bicycle is originally sold by Cervélo. The following tools and parts listed are required for these adjustments. These parts are not available for consumer purchase and are only available for purchase by Cervélo retailers. Cervélo strongly recommends that all assembly and adjustment procedures be performed by an authorized Cervélo retailer.

All parts available for separate purchase are noted in this manual with Cervélo part numbers listed in ALL - CAPS FORMAT, with a full listing provided on page 3. These parts are available by visiting the Cervelo Customer Portal <https://dealers.cervelo.com>

NOTE: All non-proprietary components such as those from Shimano or SRAM are available from your local distributor.

NOTE: This manual was developed to compliment the Cervelo General User Manual, and is intended as a supplement to the assembly and installation instructions supplied by the component manufacturers (provided with this bicycle).

Tools	
	Bicycle workstand (types which secure bike by the seatpost, or pro-type stand with fork mount)
	Torque wrench(es) with 2.5Nm to 15Nm range and adaptors:
	Allen (Hex) head inserts: 2mm, 2.5mm, 3mm, 4mm, 5mm, 6mm, 8mm, 10mm
	Torx head inserts: T25
	Open ended wrenches: 7mm, 8mm, 10mm, 17mm
	Cable cutters
	Pliers

Tools	
	Philips-head screwdriver
	Slot-head screwdriver
	Pedal wrench
	Brake rotor lockring tools
	Hydraulic bleed kit
	Di2 wire tool – Shimano
	Good quality bicycle grease

2019 S5 PARTS LIST

Item Description	Cervélo Part No.
S5 Stack Adjustment Dealer Kit	KP-0E0S5
Conventional 1 1/8" Stem Adapter	FKA-FK60-1125
Computer Mount Adapter Plate	MT-AB08-CAP
M6X1.0X14 CS028 BOLT KIT	BT-C028-14
M6X1.0X20 CS028 BOLT KIT	BT-C028-20
M6X1.0X25 CS028 BOLT KIT	BT-C028-25
M6X1.0X30 CS028 BOLT KIT	BT-C028-30
M6X1.0X35 CS028 BOLT KIT	BT-C028-35
M6X1.0X40 CS028 BOLT KIT	BT-C028-40
M6X1.0X45 CS028 BOLT KIT	BT-C028-45
Aftermarket FK60 Fork Assembly Kit 48	FKA-FK60-SM
Aftermarket FK60 Fork Assembly Kit 51	FKA-FK60-MD

Item Description	Cervélo Part No.
Aftermarket FK60 Fork Assembly Kit 54-58	FKA-FK60-LG
CS028 Stem 80mm w/ Plugs	ST-CS028-80
CS028 Stem 90mm w/ Plugs	ST-CS028-90
CS028 Stem 100mm w/ Plugs	ST-CS028-100
CS028 Stem 110mm w/ Plugs	ST-CS028-110
CS028 Stem 120mm w/ Plugs	ST-CS028-120
CS028 Stem 130mm w/ Plugs	ST-CS028-130
AB08 Mounting Kit 0mm	HBP-AB08-ZERO
AB08 Mounting Kit 2.5mm	HBP-AB08-2.5MM
AB08 Mounting Kit 2.5 Degrees	HBP-AB08-2.5DEG
AB08 Mounting Kit 5 Degrees	HBP-AB08-5DEG
AB08 Carbon Handlebar 380mm	HB-AB08-38

Item Description	Cervélo Part No.
AB08 Carbon Handlebar 400mm	HB-AB08-40
AB08 Carbon Handlebar 420mm	HB-AB08-42
AB08 Carbon Handlebar 440mm	HB-AB08-44
SP20 Carbon Post 0mm Offset w/Head	SP-SP20-ZERO
SP20 Carbon Post 25mm Offset w/Head	SP-SP20-25MM
Seat Post Clamp Assembly 0E0 S5	SPC-0E0S5
Internal Battery Mount Assembly 0E0	MT-BINT
BB Cable Guide/Cover 0E0	BBG-0E0
Chainstay Protector 0E0 S Series	PRO-CS-S
Disc Brake Hose Guide	CBG-DBH
ST28 Spacer Kit 30mm	SS-C028-KIT
Front Der Mount for 0E0 S5 w/Rivets	FDM-0E0S5

FRAME FEATURES

A guide to the Cervélo S5 frame.

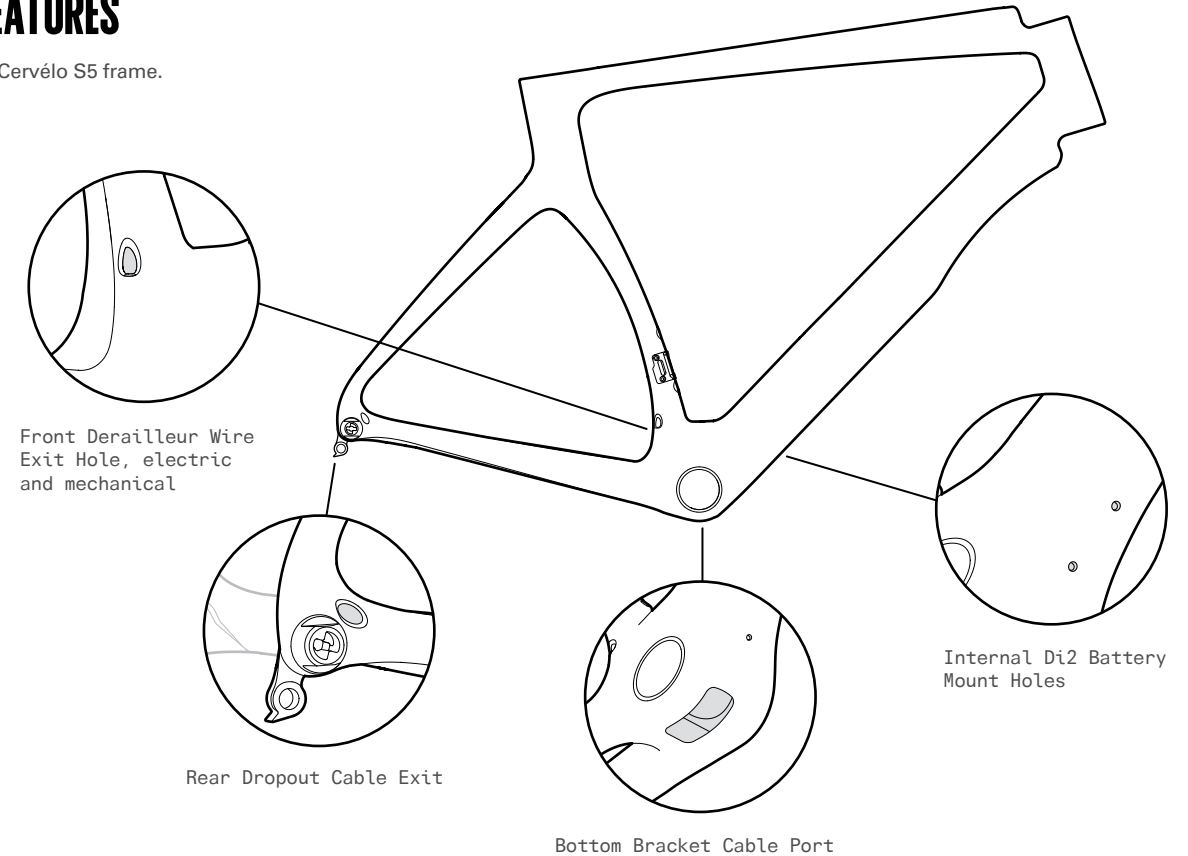

HANDLEBAR & STEM COMPONENTS

⚠ WARNING
 Only use the components specified in this manual for handlebar and stem assembly. Failure to use the specified parts and to follow the supplied assembly instructions may result in a loss of control while riding and serious injury.

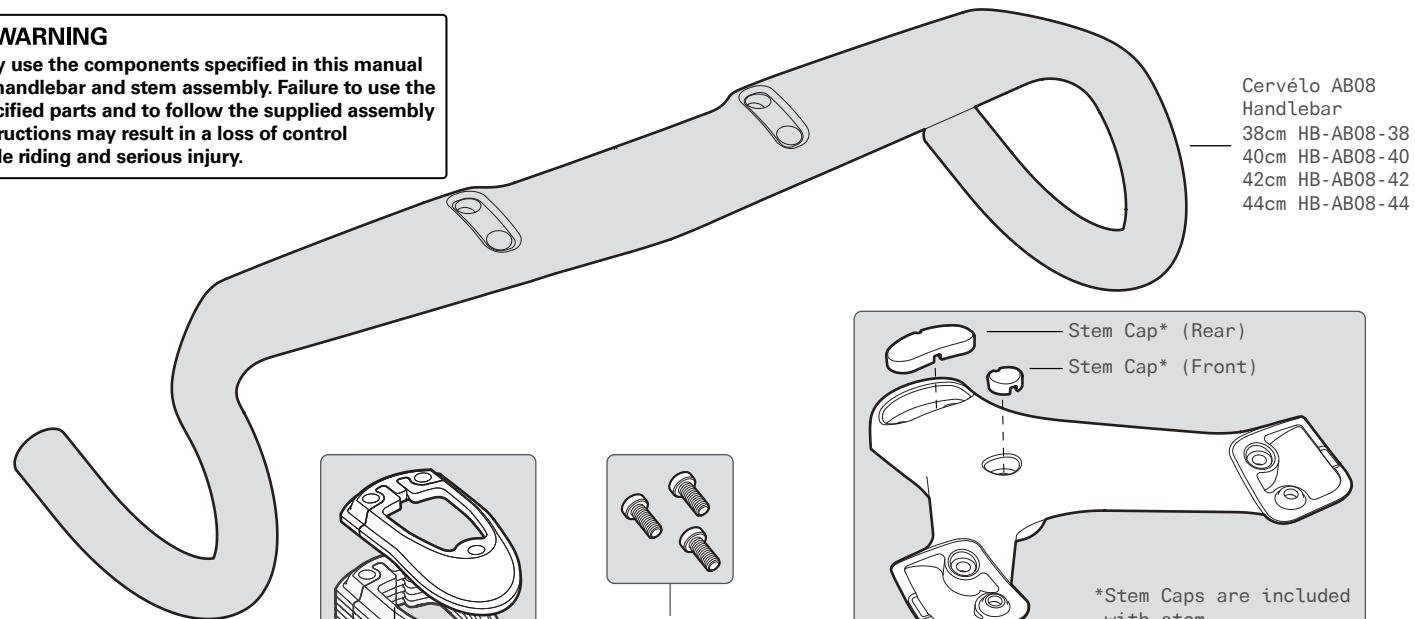

Cervélo AB08 Handlebar
 38cm HB-AB08-38
 40cm HB-AB08-40
 42cm HB-AB08-42
 44cm HB-AB08-44

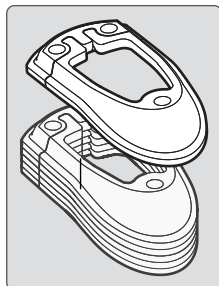
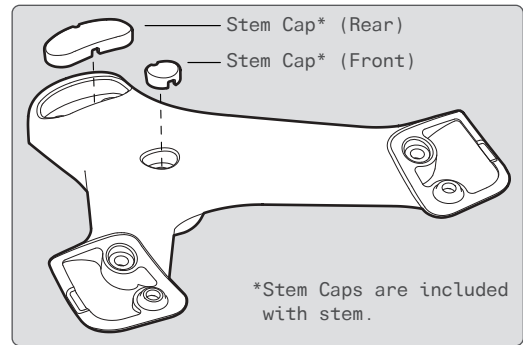

5mm Stem Spacers x6
 SS-C028-KIT

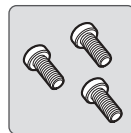

M6 Stem Fixing Screws (Sets of 3)
 0mm Stack BT-C028-14
 5mm Stack BT-C028-20
 10mm Stack BT-C028-25
 15mm Stack BT-C028-30
 20mm Stack BT-C028-35
 25mm Stack BT-C028-40
 30mm Stack BT-C028-45

Cervélo CS028 Stem
 80mm ST-CS028-80
 90mm ST-CS028-90
 100mm ST-CS028-100
 110mm ST-CS028-110
 120mm ST-CS028-120
 130mm ST-CS028-130

HANDLEBAR COMPONENTS - STACK

The AB08 handlebar stack can be increased by 2.5mm or rotated in increments of 2.5° or 5° by the use of specific Stack Spacer or Pitch Adjust Wedge kits.

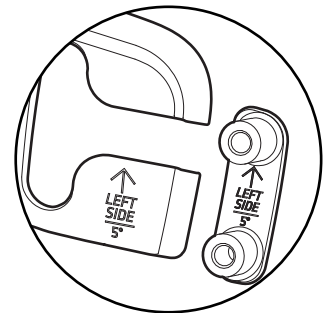

⚠ WARNING
 All handlebar mounting parts are clearly labeled for proper installation. Mixing parts will void warranty and may result in injury.

NOTE: Refer to page 25 for installation instructions of the stack or pitch adjust wedge kits.

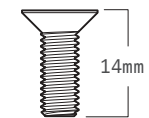

Bar Fixing Screw
 M5 x 14mm
 Actual Size

0mm Stack Kit

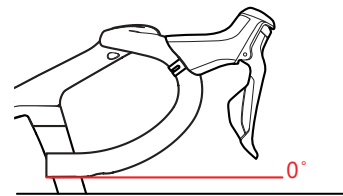

- Handlebar Fixing Nuts (L + R) for 0mm stack
 - M5 x 14mm Bolts (x4)

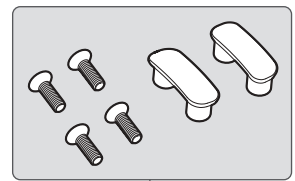

HBP-AB08-ZERO

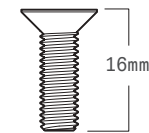

Bar Fixing Screw
 M5 x 16mm
 Actual Size

2.5mm Stack Kit

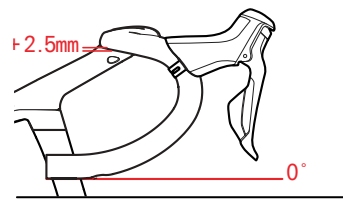

- Handlebar Fixing Nuts (L + R) for 2.5mm stack
 - 2.5mm Bar Spacers (L + R)
 - M5 x 16mm Bolts (x4)

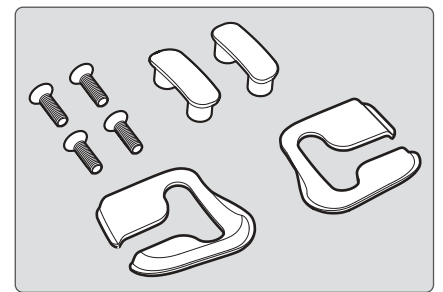

HBP-AB08-2.5MM

HANDLEBAR COMPONENTS - PITCH ADJUST



⚠ WARNING
Complete Handlebar Stack Spacer or Pitch Adjust Wedge kits must be utilized without substitution or combination of parts. Failure to use the specified parts and to follow the supplied assembly instructions may result in a loss of control while riding and potentially serious injury.

2.5° Pitch Adjust Kit

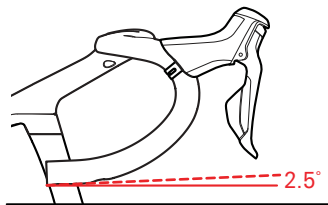

- Handlebar Fixing Nut (L + R) for 2.5° rotation
- 2.5° Pitch Adjust Wedge (L + R)
- M5 x 16mm Bolts (x4)

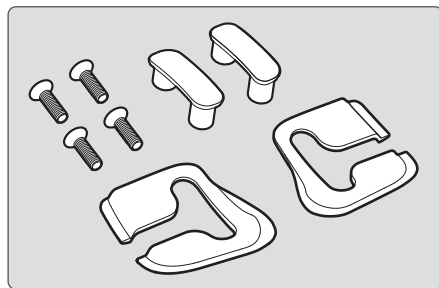

HBP-AB08-2.5DEG

5° Pitch Adjust Kit

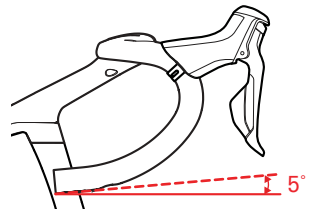

- Handlebar Fixing Nuts (L + R) for 5° rotation
- 5° Pitch Adjust Wedge (L + R)
- M5 x 16mm Bolts (x4)

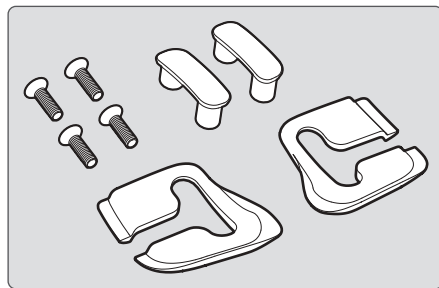

HBP-AB08-5DEG

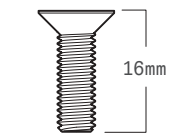

Bar Fixing Screw
M5 x 16mm
Actual Size

FORK & HEADSET COMPONENTS

⚠ WARNING
Your Cervélo frame & fork have been designed to work together. Do not attempt to install an alternative fork.



NOTE: The S5 headset assembly does not require a compression ring.

Fit Top Bearing Dust Seal to Fork Topper before installation.

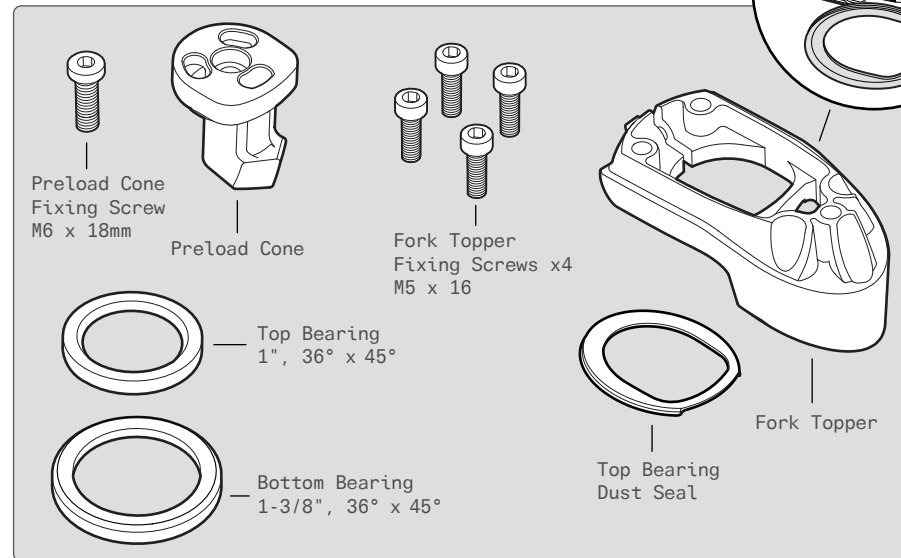

FK60 Fork Assembly Kit
FKA-FK60-SM
FKA-FK60-MD
FKA-FK60-LG

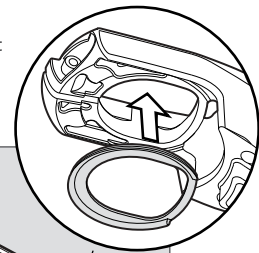

SMALL PARTS

Designed to accommodate electronic, mechanical and hydraulic controls, the S5 frame is engineered to provide seamless integration of all shifting systems, regardless of method or brand. In order to do so, you will require the parts shown below. Not all parts will be used, depending on the groupset fitted to the bicycle.

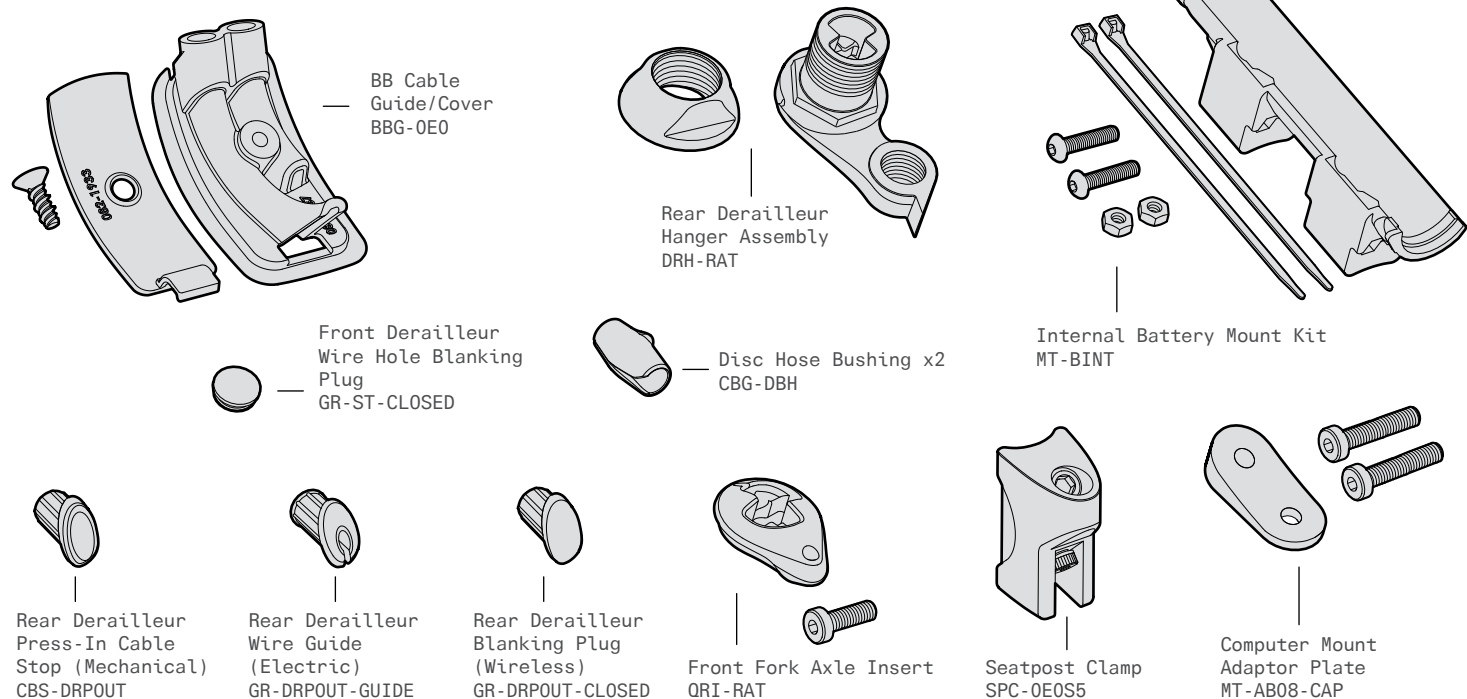

FRAME PREPARATION

1. Apply carbon paste to both frame and seatpost.
2. Insert Seatpost Clamp (SPC-0E0S5) fully into frame so it is fully flush with the top tube.
3. Adjust height and torque to 8Nm maximum.

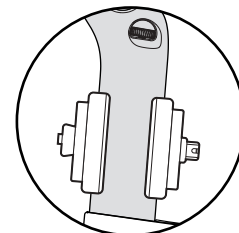
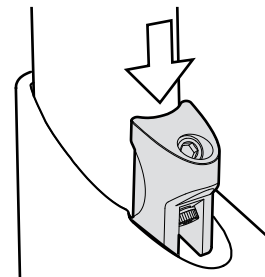

⚠ WARNING
Hold the frame using a secured seatpost only.

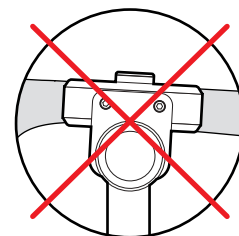

⚠ WARNING
Clamping the top tube can damage the frame and void your warranty.

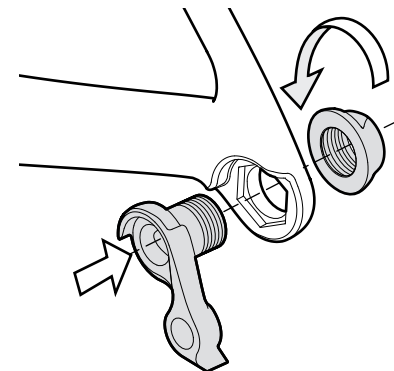

Lightly grease Rear Derailleur Hanger Fixing Nut and install Rear Derailleur Hanger (DRH-RAT for Cervélo Rapid Axle) finger tight. Final tightening will be done after rear wheel installation.

⚠ WARNING
Do not final tighten rear derailleur hanger assembly without rear wheel installed. Doing so will result in a misaligned derailleur and poor shifting.

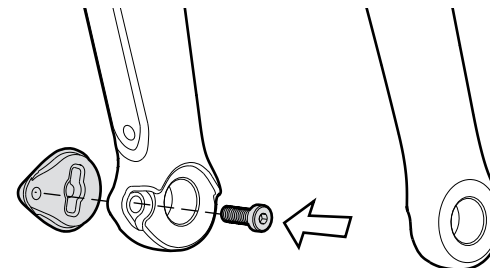

Lightly grease supplied M4 fixing screw, and install the Front Fork Axle Insert (QRI-RAT for Cervélo Rapid Axle) to the fork. Tighten to 3Nm.

S5 ASSEMBLY OVERVIEW

NOTE: See the following pages for more detailed assembly instructions.

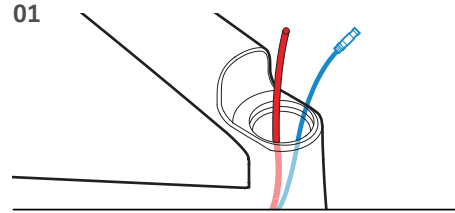

01 Prepare the frame by installing the rear brake hose and derailleur controls, exiting the frame through the upper surface of the headtube. **Do not trim.**

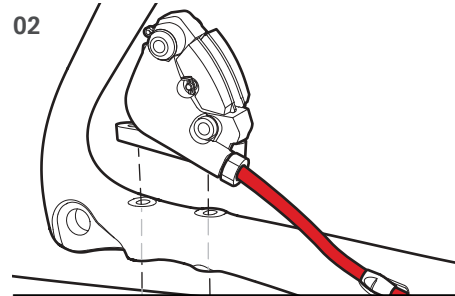

02 Attach the rear brake caliper according to brake manufacturer directions. Derailleur control wires can either be attached at this point, or remain exposed through the Bottom Bracket Cable Port.

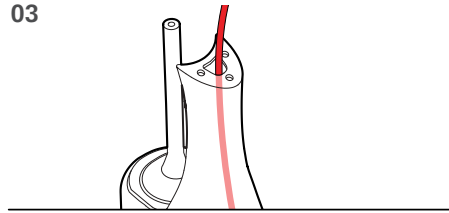

03 Prepare the fork by installing the brake hose from the lower leg hose passage, exiting through the top of the leading edge of the fork.

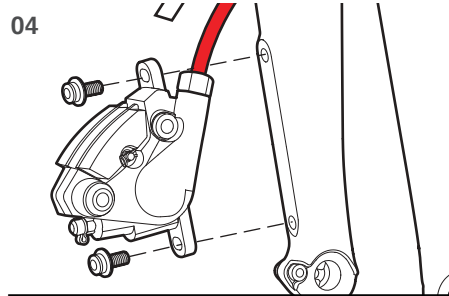

04 Attach the front brake caliper according to brake manufacturer directions.

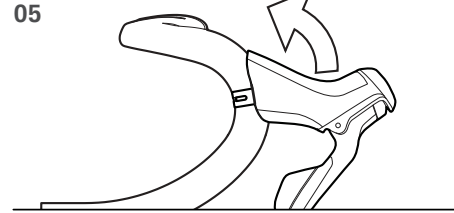

05 Prepare the handlebar by installing the shift/brake levers.

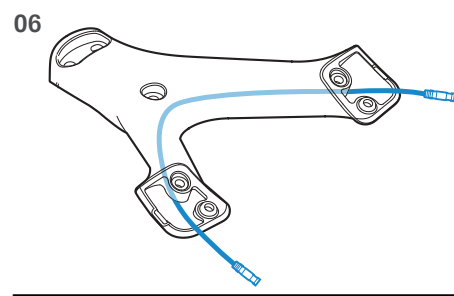

06 For Di2 builds, prepare the stem, by routing the 750mm length E-Wire so it passes through both blades, with the connector ends exposed at the handlebar end of each port.

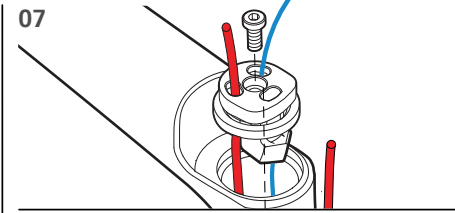

07 Grease the bearing cups in the frame, then install bearings. Feed brake hose and derailleur controls through Preload Cone. Install fork and tighten Preload Cone until fork has no play but still rotates smoothly. **Refer to page 20.**

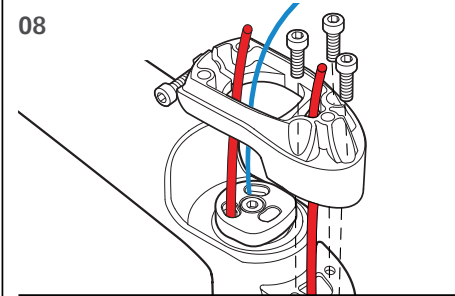

08 Feed hoses and derailleur controls through Fork Topper. Use the supplied M5 x 16mm screws to secure fork. **Refer to page 21.**

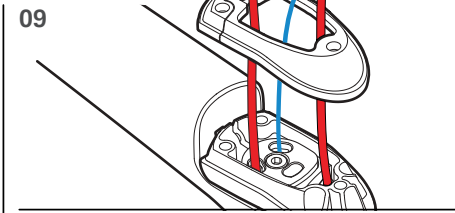

09 Feed cables and hoses through desired amount of 5mm Stem Spacers.

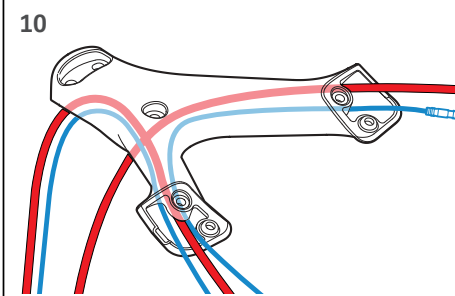

10 Install the stem so that the brake hoses pass through the appropriate blades. E-Wire travels up through the right hand blade. With mechanical controls the rear housing is on the right and the front on the left.

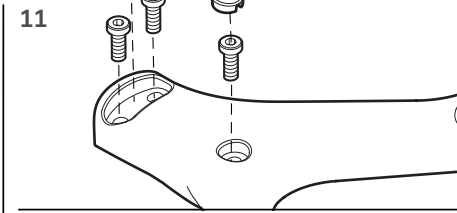

11 Ensure you have the correct length bolts, apply Loctite 242 and secure the stem and stem spacers to the ForkTopper. **Refer to pages 22-24.**

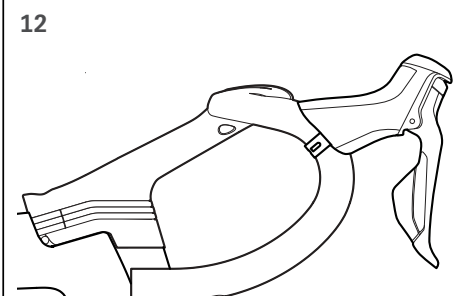

12 Install handlebar and connect the controls. **Refer to page 25.**

BEFORE YOU BUILD

- While the two-piece 5mm Stem Spacers allow for addition/removal without re-cabling the bike, the length of the cables used during first assembly will dictate how much adjustment is possible later on.
- After first assembly it is simpler to remove Stem Spacers (go lower) and trim the hydraulic brake hose at the brake lever as required.
- Adding spacers after first assembly (go higher) may require replacement of the cables to get the required length.
- Whenever possible, it is best to establish the correct fit before performing final cabling of the S5.

Here are a few tricks that we have learned along the way that may help with reinstallation:

Before reinstalling the stem with no spacers:

- Loosen the handlebar fixing screws a few turns.
- In order to avoid pinching the rear brake hose during reinstallation of the stem, simply remove the rear brake caliper from the frame and draw the extra hose length out, by gently pulling the caliper toward the rear of the bike.
- Taking care not to kink the derailleur housing (if using mechanical), carefully reinstall the stem by feeding the extra hoses into the frame, and tighten the stem fixing bolts to 7Nm.
- Reinstall the rear brake caliper by pushing the extra housing into the frame.
- Ensure the hoses and housings are located in the appropriate slot in the bar, and tighten the handlebar fixing bolts to 5Nm.

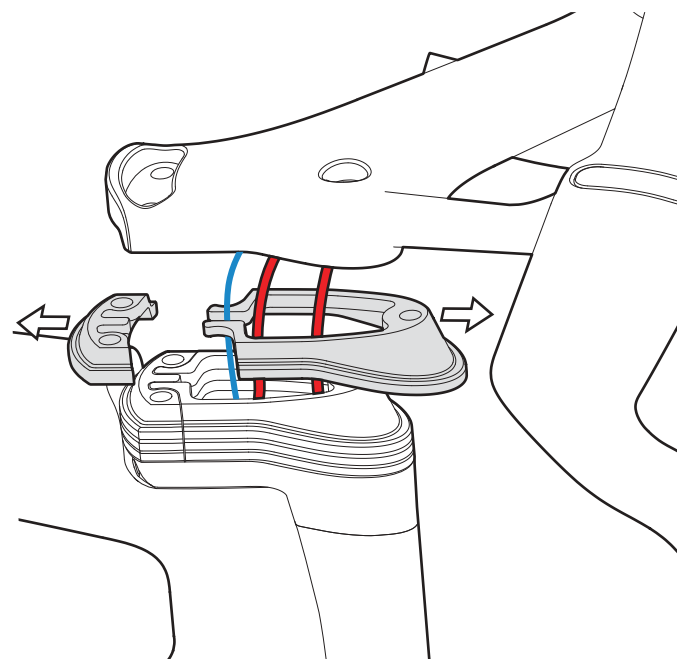

⚠ WARNING

Do not attempt to force hydraulic brake hose that will not slide smoothly into the frame through the fork topper/head tube. This may result in the cables becoming kinked or cracked, and cause a fluid leak which can result in a loss of brake function and a risk of serious injury.

ELECTRIC CABLE PREPARATION

● Brake ● E-Wire

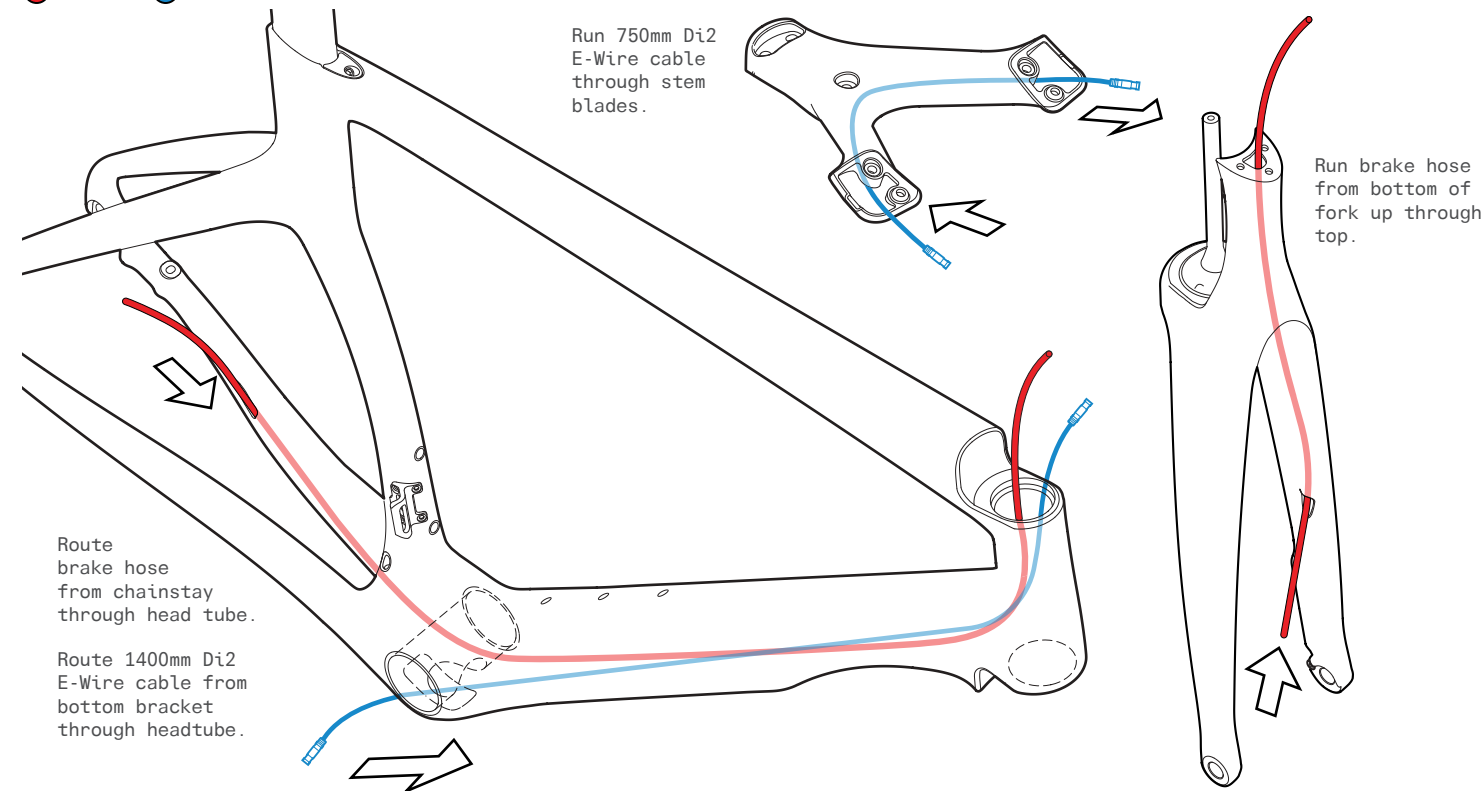

MECHANICAL CABLE PREPARATION

● Brake ● Rear Shifter ● Front Shifter

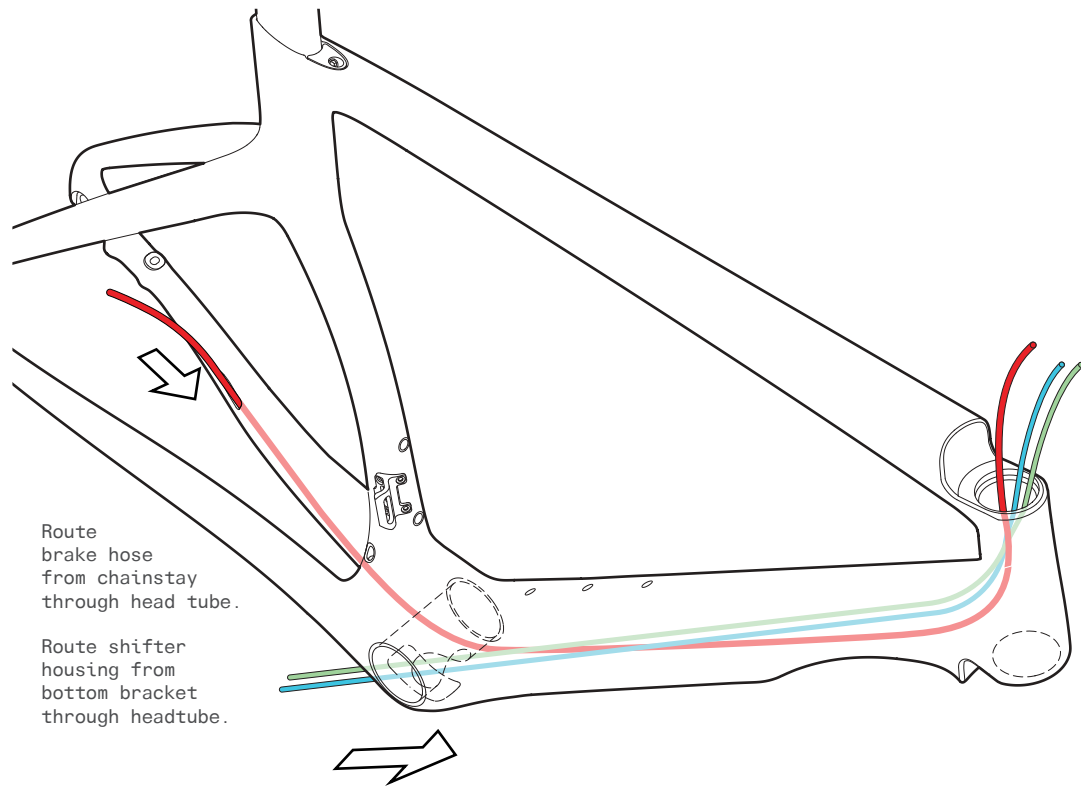

BRAKE HOUSING ROUTING

It is recommended that the hydraulic brake hoses or brake cable housing is installed first. These routing illustrations are intended as a supplement to the manufacturer's installation instructions only. For both hydraulic and mechanical disc brakes, please refer to the component manufacturer's service center or website for further information.

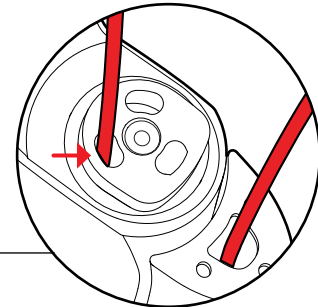
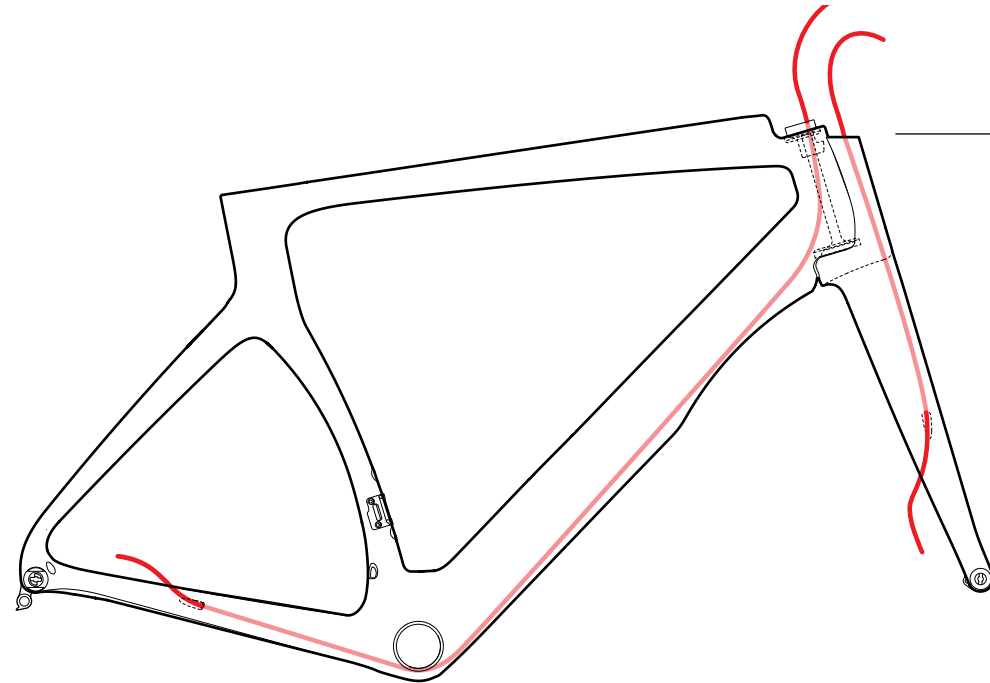
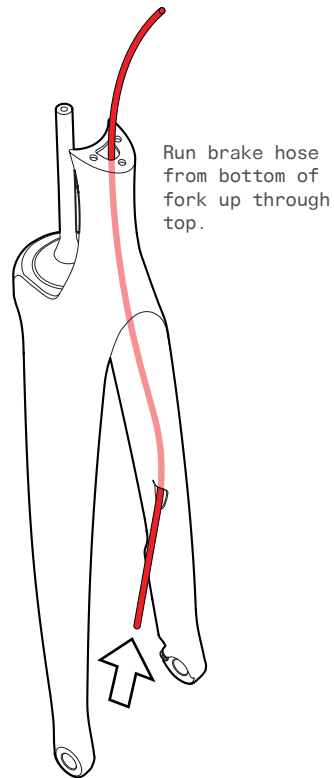

Electric: Route rear brake hose through the right Preload Cone pass-through.

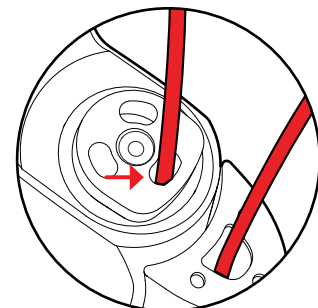

Mechanical: Route rear brake hose through the front Preload Cone pass-through.

BRAKE HOUSING ROUTING

Route hydraulic brake hose or mechanical brake housing through the frame and fork with the Disc Hose Bushings (CBG-DBH). Install and adjust calipers as per manufacturer's instructions.

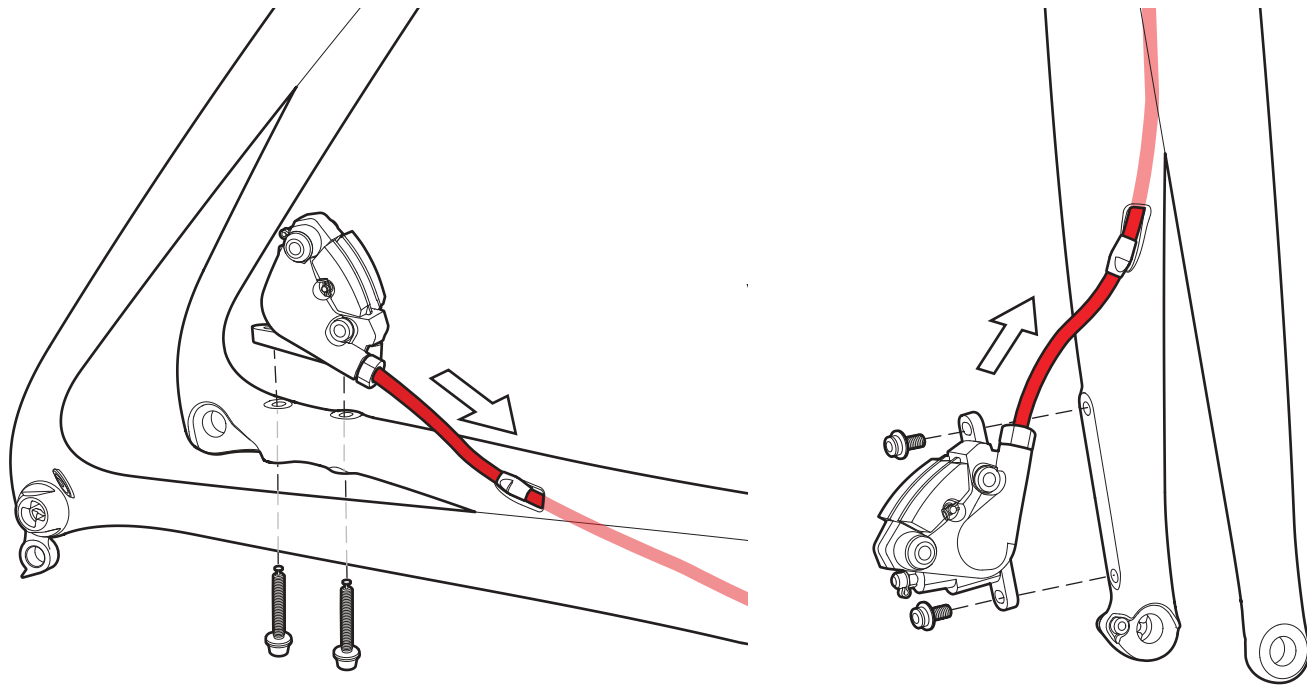

ELECTRIC CABLE ROUTING

It is recommended that electric cabling and junction points be installed after the brake hose has been installed. These routing illustrations are intended as a supplement to the manufacturer's installation instructions only. Please refer to the component manufacturer's service center or website for further information.

● Brake ● E-Wire

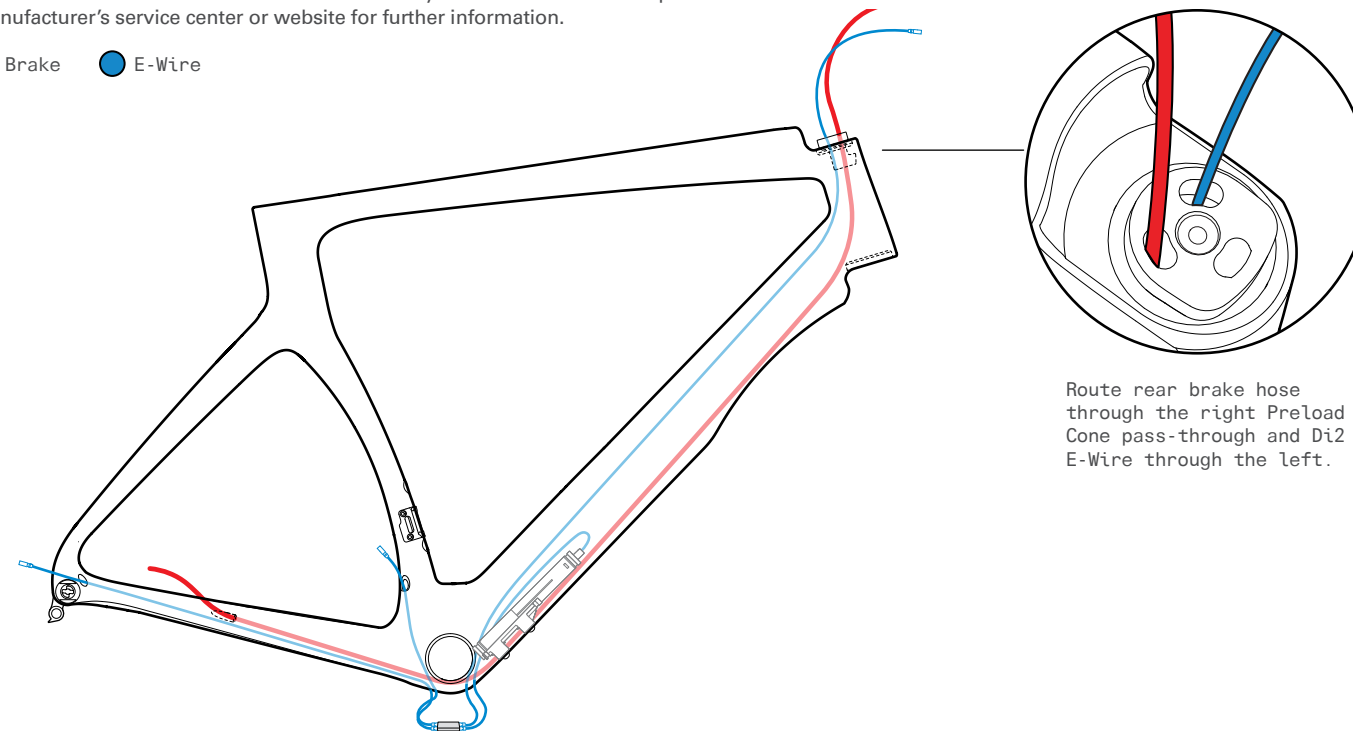

Route rear brake hose through the right Preload Cone pass-through and Di2 E-Wire through the left.

MECHANICAL CABLE ROUTING

It is recommended that front and rear derailleur cables be installed after the brake hose has been installed. These routing illustrations are intended as a supplement to the manufacturer's installation instructions only. Please refer to the component manufacturer's service center or website for further information.

● Brake ● Rear Shifter ● Front Shifter

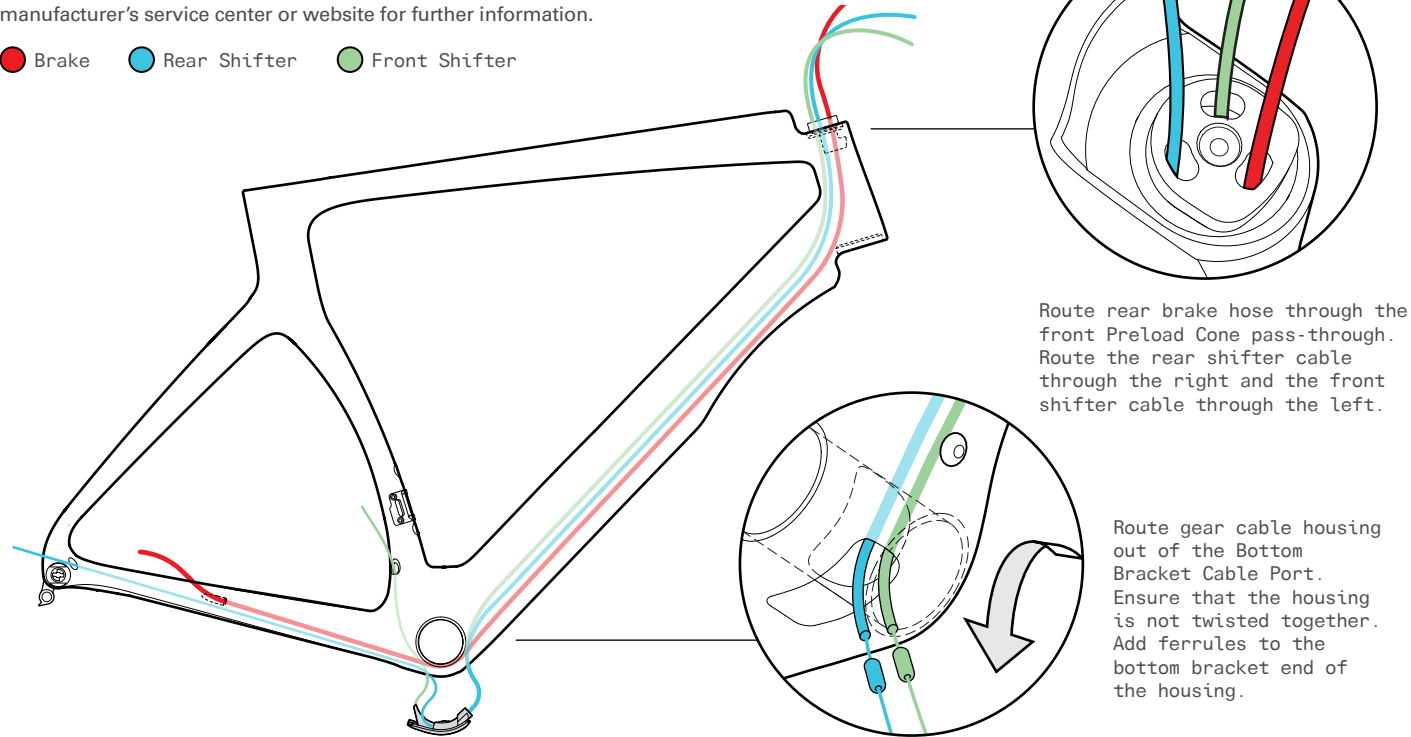

Route rear brake hose through the front Preload Cone pass-through. Route the rear shifter cable through the right and the front shifter cable through the left.

Route gear cable housing out of the Bottom Bracket Cable Port. Ensure that the housing is not twisted together. Add ferrules to the bottom bracket end of the housing.

FORK INSTALLATION

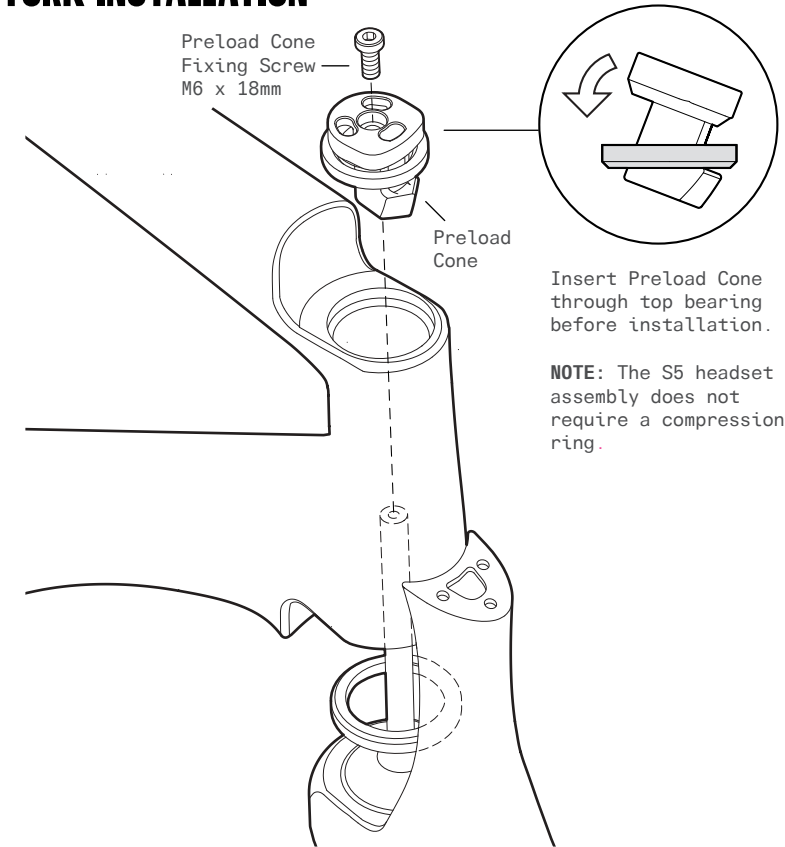

Insert Preload Cone through top bearing before installation.

NOTE: The S5 headset assembly does not require a compression ring.

- Note:** It is recommended that you familiarize yourself with the steering system before complete installation, by performing a trial assembly without hoses or control cables present.
1. Check the headset components to ensure there are no sharp or rough edges on any of the surfaces which could impact fit or alignment of the bearing components. If any rough edges are detected, have the components repaired (sharp edges removed) or replaced before proceeding.
 2. Install upper bearing on Preload Cone, and press bearing into lightly greased upper bearing pocket.
 3. Press lower bearing into lightly greased lower bearing pocket.
 4. Lightly grease the upper 10mm of the fork tension rod.
 5. Insert fork by sliding tension rod through the bearings, so that the lower bearing mates on the lower fork bearing surface, and the tension rod locates in the Preload Cone.
 6. Install M6 preload screw and tighten to remove play from the system. Final adjustment will be done after installation of the ForkTopper.

NOTE: This diagram is for assembly reference only. During complete assembly, hoses and control cables will be present.

FORK TOPPER INSTALLATION

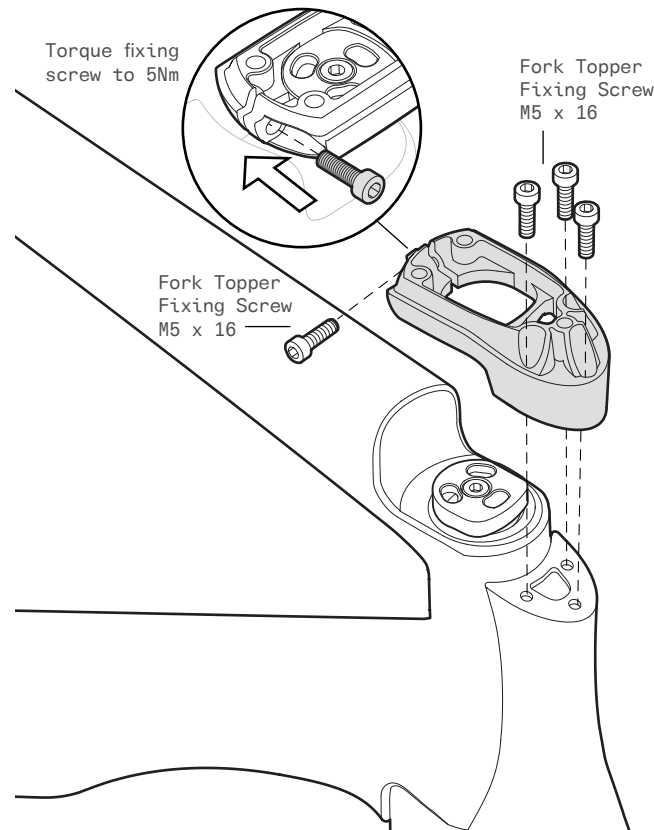

Note: It is recommended that you familiarize yourself with the steering system before complete installation, by performing a trial assembly without hoses or control cables present.

1. Locate Fork Topper on fork, so that the Preload Cone is captured and the three forward fixing screw holes align with the threaded fork inserts. Note, if these do not line up, ensure that the Fork Topper is the correct match to the frame/fork size.
2. Use 3 of the supplied M5 x 16mm fixing screws, to attach the Fork Topper to the fork and torque to 10Nm.
3. Install the remaining M5 x 16mm fixing screw in Fork-Topper, adjust preload screw to remove any play in the bearing, and torque pinch bolt to 5Nm.

NOTE: This diagram is for assembly reference only. During complete assembly, hoses and control cables will be present.

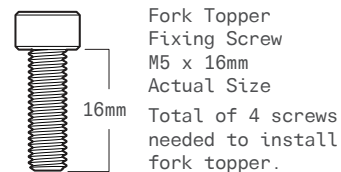

STEM INSTALLATION

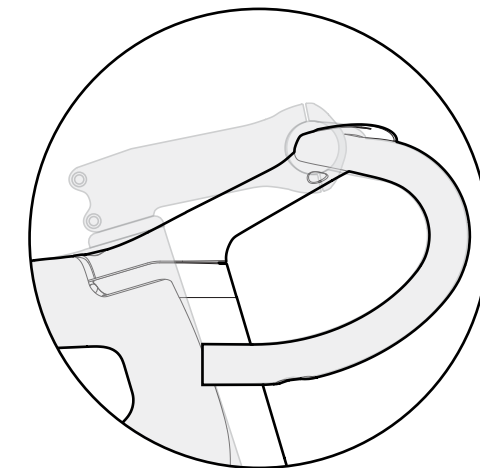
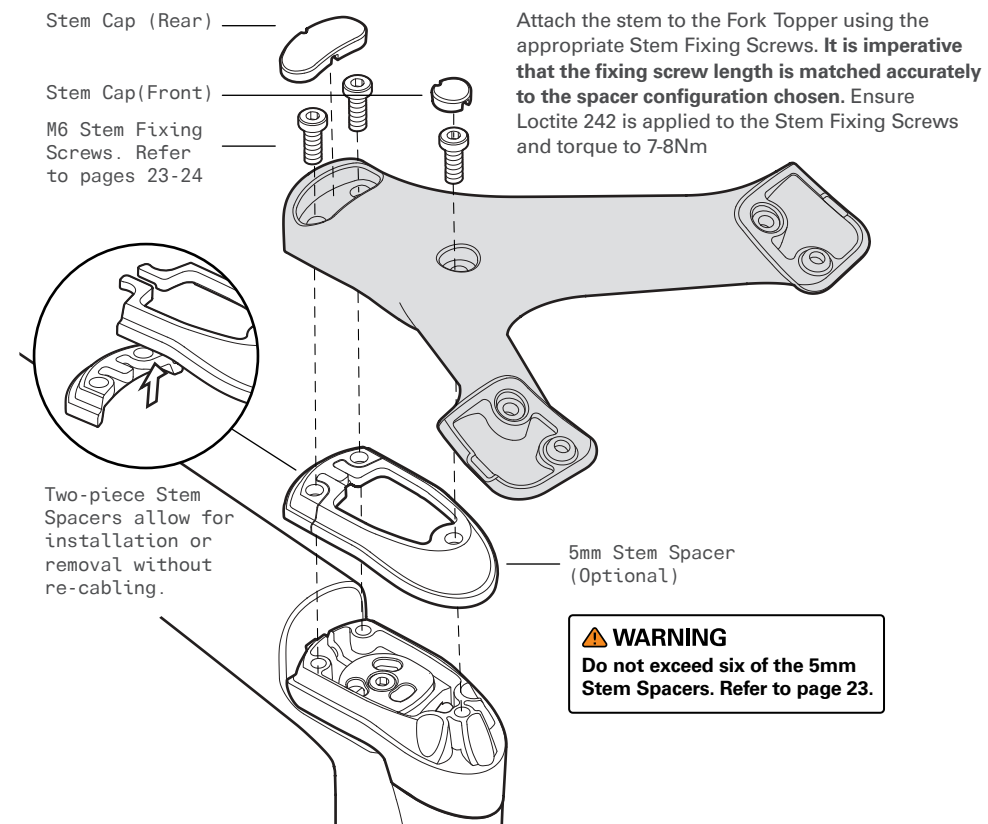

Base position for the S5 stem and handlebar matches that of the previous edition S5 with a 6" stem and a 5mm top cap.

NOTE: This diagram is for assembly reference only. During complete assembly, hoses and control cables will be present.

STACK ADJUSTMENT

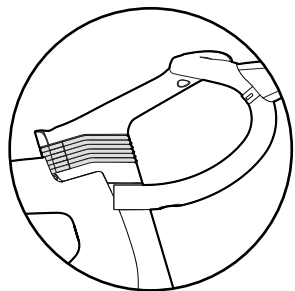

⚠ WARNING
 To ensure rider safety, it is critical that the supplied fixing screws be used, and matched to the indicated spacer size and configuration. Failure to do so may result in catastrophic failure of the steering mechanism, and injury to rider.

NOTE: Maximum stem stack adjustment is 30mm. This requires the use of all six 5mm Stem Spacers.

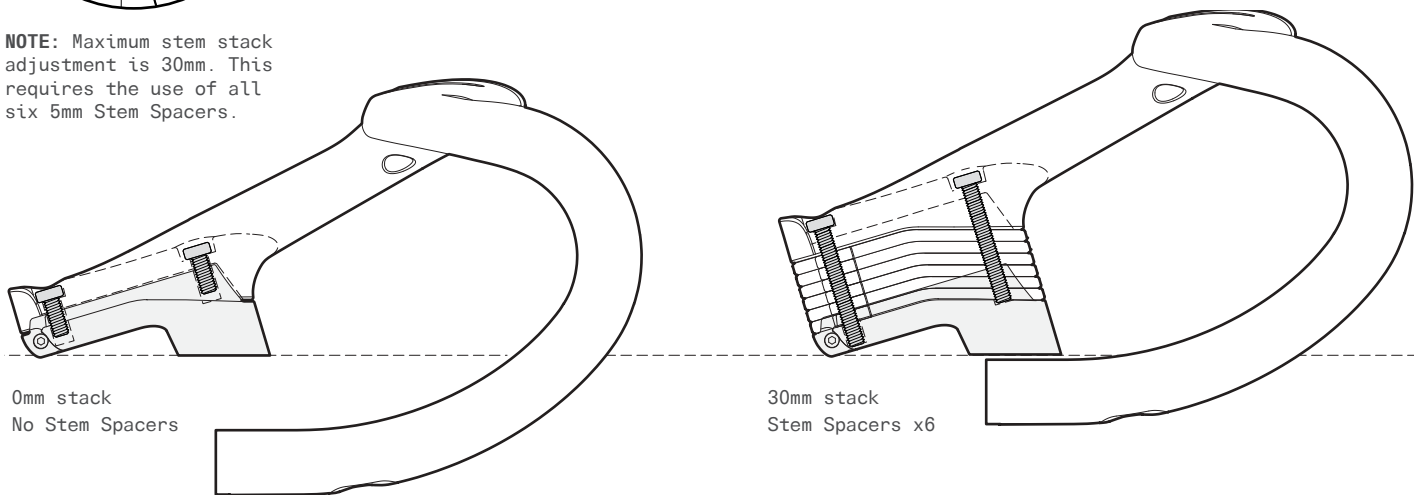

STEM FIXING SCREW GUIDE

M6 Stem Fixing Screws
 Actual Size

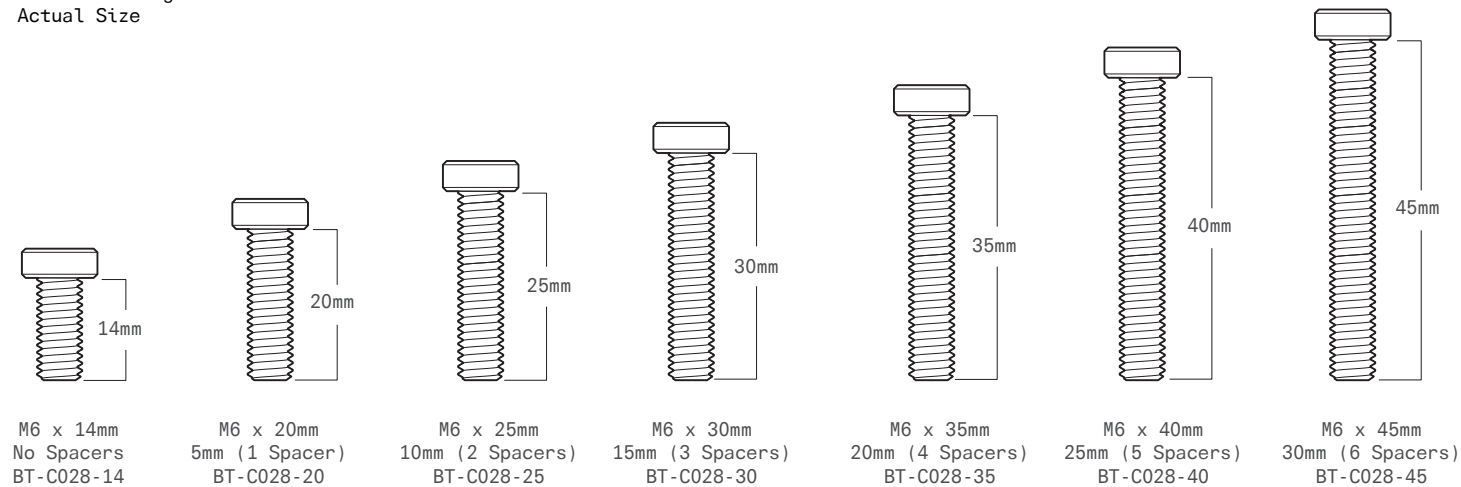

HANDLEBAR INSTALLATION

Using the supplied M5 Handlebar Fixing Screws, attach handlebar to stem with the Handlebar Fixing Nuts. Ensure that chosen Fixing Screws and Handlebar Fixing Nut match the Stack or Pitch Adjust Wedge chosen. Torque to 6-6.5Nm.

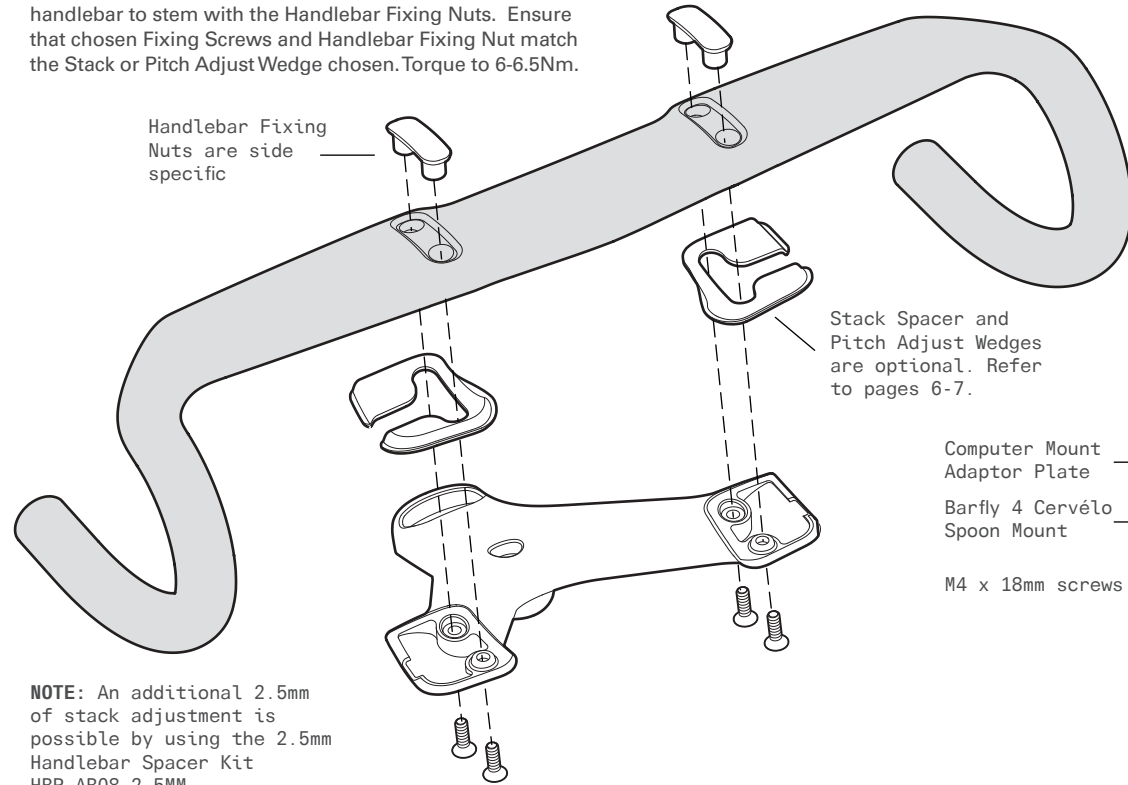

NOTE: An additional 2.5mm of stack adjustment is possible by using the 2.5mm Handlebar Spacer Kit HBP-AB08-2.5MM

⚠ WARNING
Complete Handlebar Stack Spacer or Pitch Adjust Wedge kits must be utilized without substitution or combination of parts. Failure to use the specified parts and to follow the supplied assembly instructions may result in a loss of control while riding and potentially serious injury.

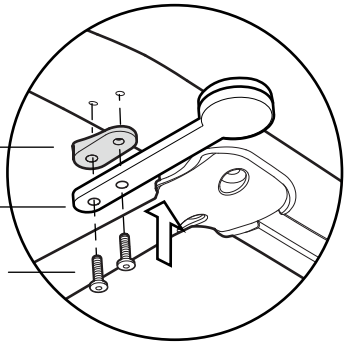

Use the Computer Mount Adaptor Plate (MT-AB08-CAP) and two M4 x 18mm screws to attach the Barfly 4 Cervélo Spoon Bar/Stem Mount. Torque screws to 3Nm.

HANDLEBAR & STEM - ELECTRIC CABLE ROUTING

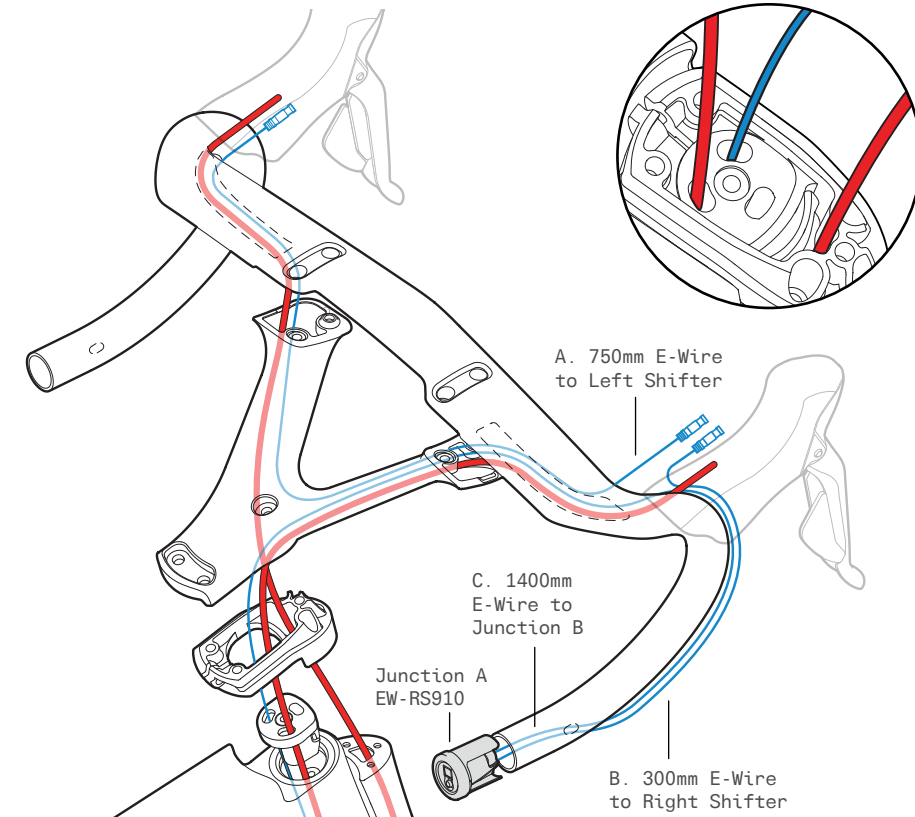

● Brake
 ● E-Wire

1. Install shifters on handlebar and connect Left and Right using the 750mm E-Wire A
2. Install 300mm E-Wire B connecting Junction A (EW-RS910) to Right shifter.
3. Thread 1400mm E-Wire C from frame, through right hand blade of the stem.
4. Thread brake hoses through the appropriate blades of the stem.
5. Install stem and optional 5mm Stem Spacers to Fork Topper ensuring that the appropriate fixing screws are used in consideration of spacer configuration. Refer to pages 23-24.
6. Attach handlebar to stem, and attach brake and shifting controls as per manufacturer's instructions. Refer to page 25.

HANDLEBAR & STEM - MECHANICAL CABLE ROUTING

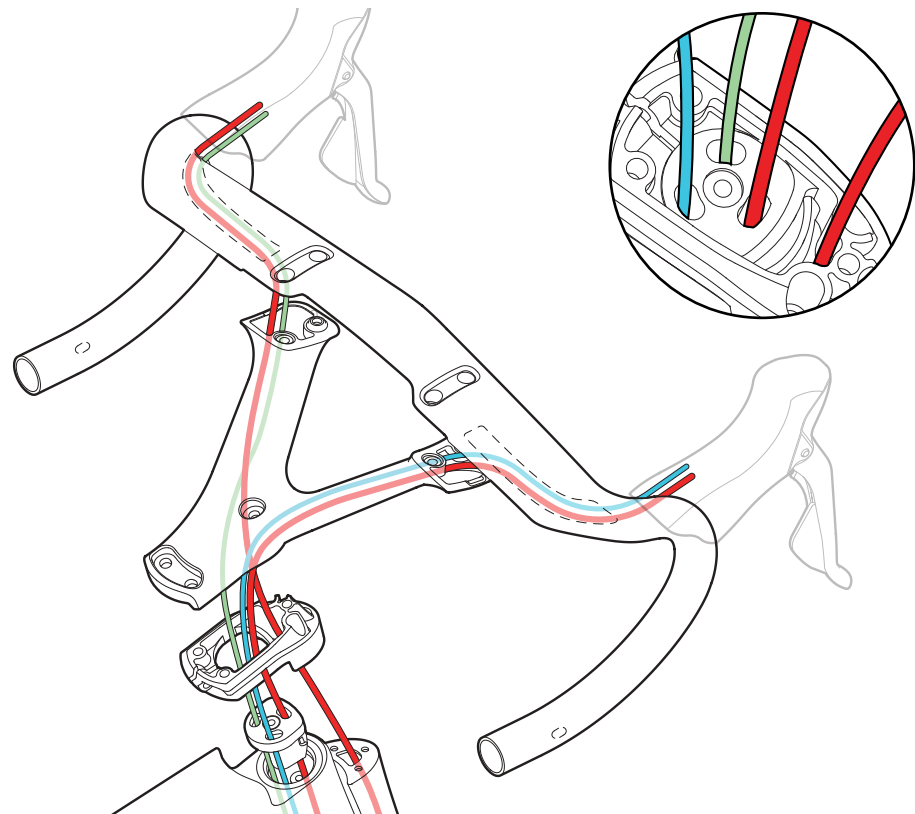

- Brake
- Rear Shifter
- Front Shifter

1. Install shifters on handlebar.
2. Thread exposed shifter housing through the appropriate blades of the stem. (right/rear, left/front).
3. Thread brake hoses through the appropriate blades of the stem.
4. Install stem and optional 5mm Stem Spacers for Fork Topper ensuring that the appropriate fixing screws are used in consideration of spacer configuration. Refer to pages 23-24.
5. Attach handlebar to stem, and attach brake and shifting controls as per manufacturer's instructions. Refer to page 25.

DI2 BATTERY INSTALLATION

The battery for your Shimano Di2 system mounts inside the down tube using the Internal Battery Mount (MT-BINT) designed to fit this frame. As this is a sealed location, it is important to test the system prior to final installation.

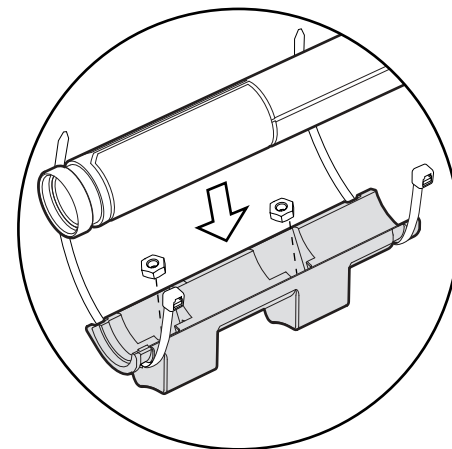

Press the two M3 fixing nuts into the holder through the upper holes. Attach battery to mount using two zip ties, and install.

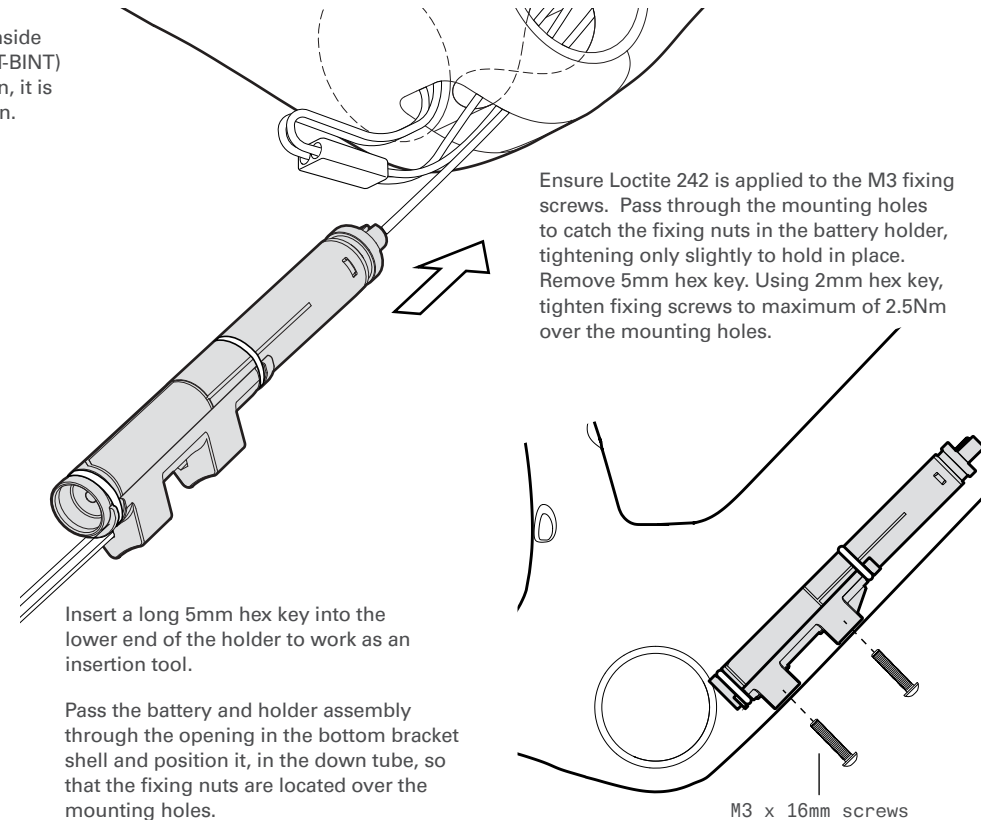

Insert a long 5mm hex key into the lower end of the holder to work as an insertion tool.

Pass the battery and holder assembly through the opening in the bottom bracket shell and position it, in the down tube, so that the fixing nuts are located over the mounting holes.

Ensure Loctite 242 is applied to the M3 fixing screws. Pass through the mounting holes to catch the fixing nuts in the battery holder, tightening only slightly to hold in place. Remove 5mm hex key. Using 2mm hex key, tighten fixing screws to maximum of 2.5Nm over the mounting holes.

M3 x 16mm screws

ELECTRIC CABLE INSTALLATION

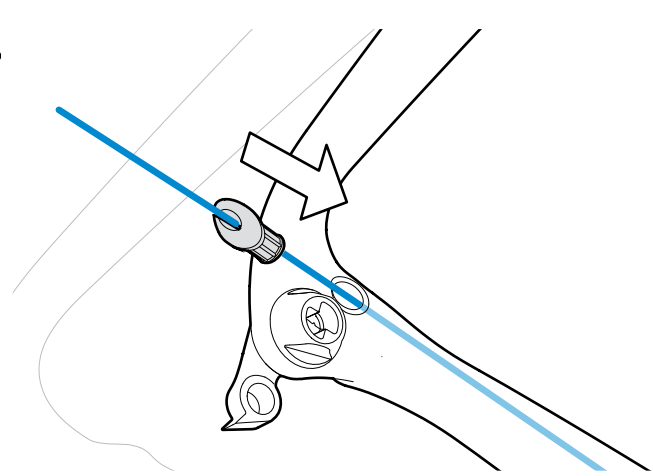
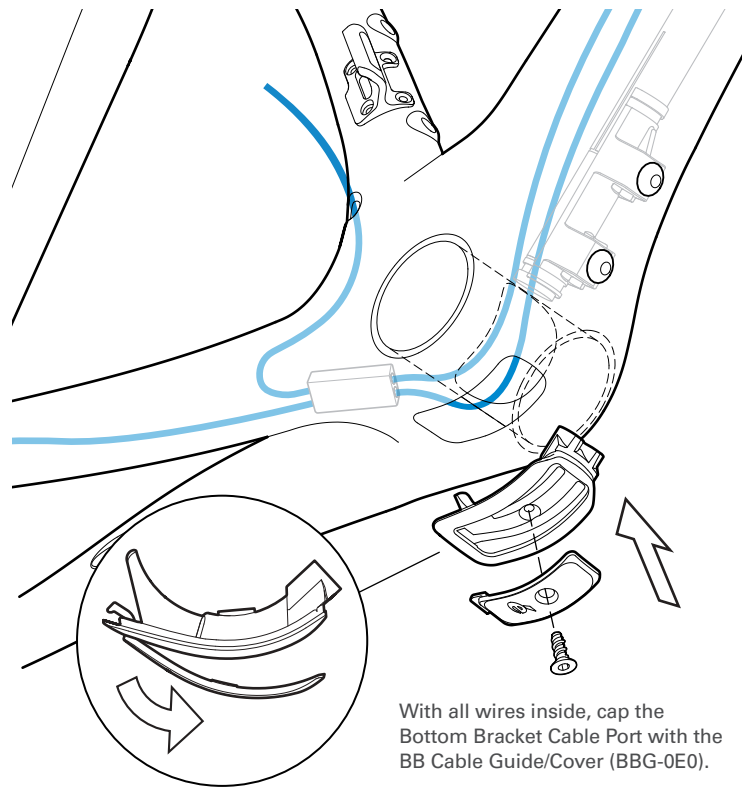

For wireless shifting systems install the Rear Derailleur Blanking Plug (GR-DRPOUT-CLOSED).

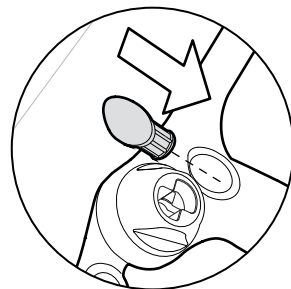

MECHANICAL CABLE INSTALLATION

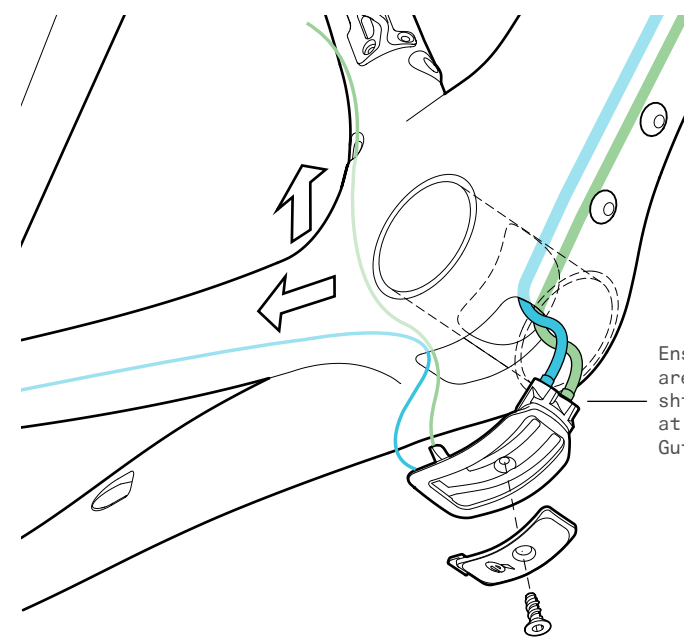

The front cable travels across the non-drive side slot, and in the direction of the seat tube. The rear cable travels along the drive side slot, and along the chainstay. When complete, fix the BB Cable Guide/Cover (BBG-0E0) into place.

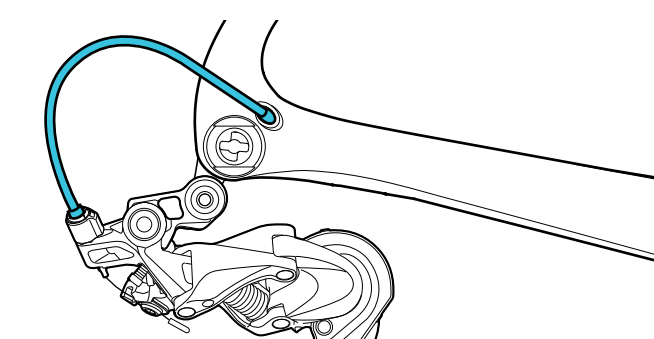
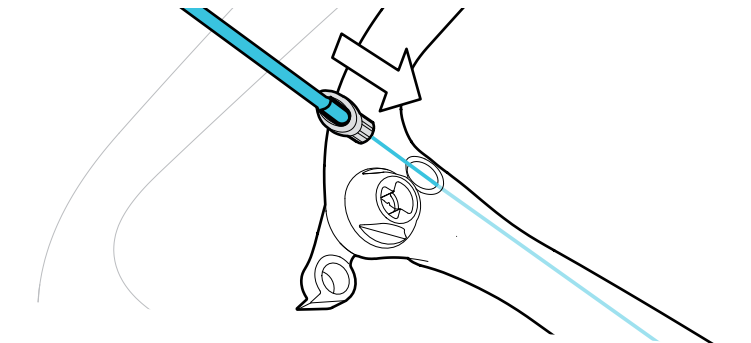

SEATPOST ASSEMBLY

1. Ensure Loctite 242 is applied to threads below the head of the 45mm button head cap screw. Install cross bar on 45mm button head cap screw and torque to 3Nm.
2. Ensure Loctite 242 is applied to both fixing screw threads.
3. Install the curved washer and adjustment dial in the seatpost cutout.
4. Install the button head cap screw with crossbar installed, and turn the dial until threads are engaged.
5. Install the spherical washer on the 35mm spherical cap screw, so that the concave face, mates with the convex surface of the screw.
6. Install cross bar.
7. Apply light coat of carbon assembly compound to the radius on the upper face of the seatpost.
8. Install the lower saddle clamp base, as per the diagram.
9. Locate saddle rails between upper and lower clamping surfaces.
10. Establish desired saddle angle by first using adjustment wheel.
11. Tighten opposing angle adjusting screw to secure saddle at 8-9Nm.

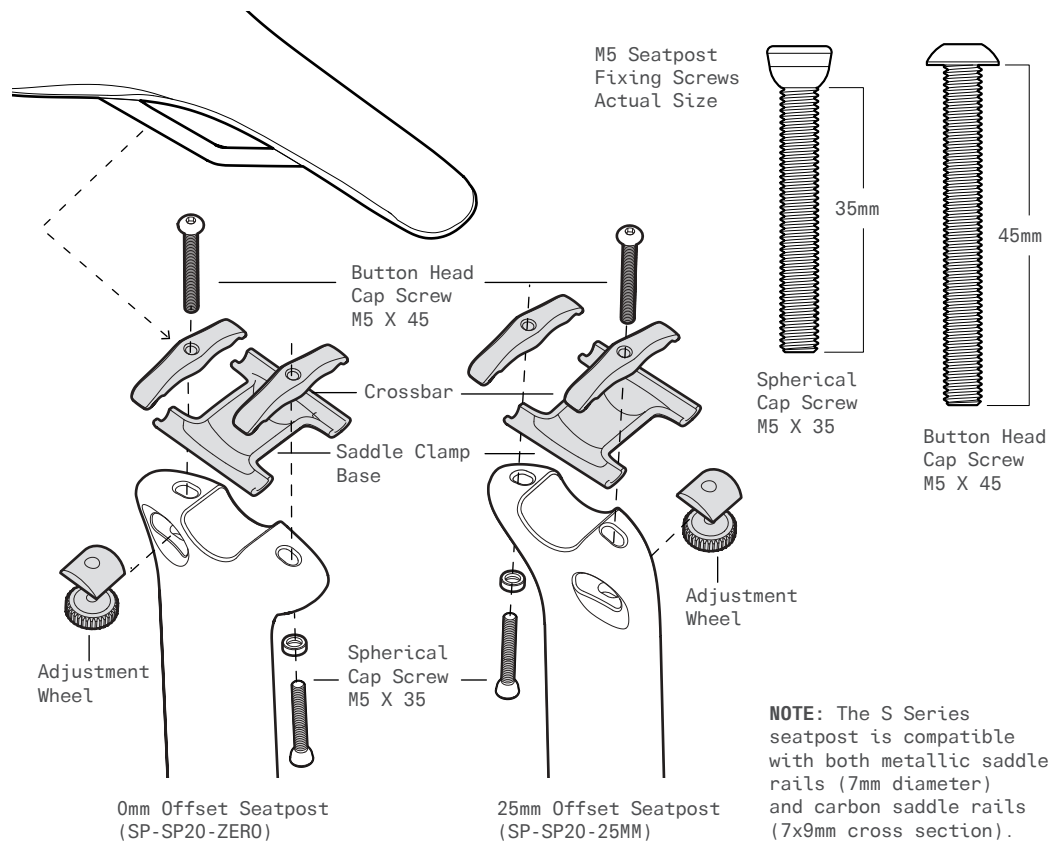

SEATPOST CUTTING INSTRUCTIONS

Note: It is essential that all Cervélo Aero Seatposts, have a 45 degree chamfer cut on the rear trailing edge of the post. If trimming is required after fitting, the following method is recommended.

1. Taking care to maintain the minimum required seatpost insertion of 6.5cm and maximum of 8.5cm, carefully measure and use a light coloured grease pencil to accurately mark the cut-off location on the seatpost.
2. Insert the S Series Seatpost in the ParkTool SG-7.2 Saw Guide (or equivalent) so that the cut-off line can be seen clearly through the blade guide in the tool.
3. Using a blade designed specifically for cutting carbon composite materials (or a fine tooth blade with greater than 32 teeth per inch); proceed with cutting the Seatpost (as per ParkTool's instructions).
4. Use fine grit sandpaper to carefully remove any fraying or burring from the cut end. Reposition clamp approximately 10cm from the cut end.
5. With a grease pencil, mark a point 1cm from the cut end on the trailing edge of the Seatpost, and another 1cm from the back, on the bottom edge. Draw a line connecting them, forming a 45 degree guideline.
6. Placing the blade of your saw on the grease pencil mark, very carefully proceed to cut, resulting in a 45 degree chamfer being cut onto the trailing edge of the Seatpost.
7. Carefully sand the end and after applying carbon assembly compound, return to the frame.

⚠ WARNING

If trimming is required, final length should allow for a minimum 6.5cm of seatpost remaining in the frame. Failure to meet this requirement, may result in damage to the frame not covered by warranty policy, or serious injury to rider.

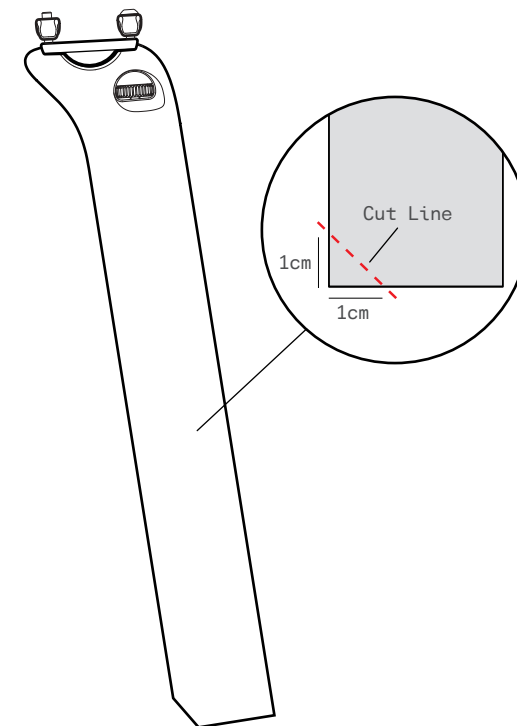

FRAME PROTECTION INSTALLATION

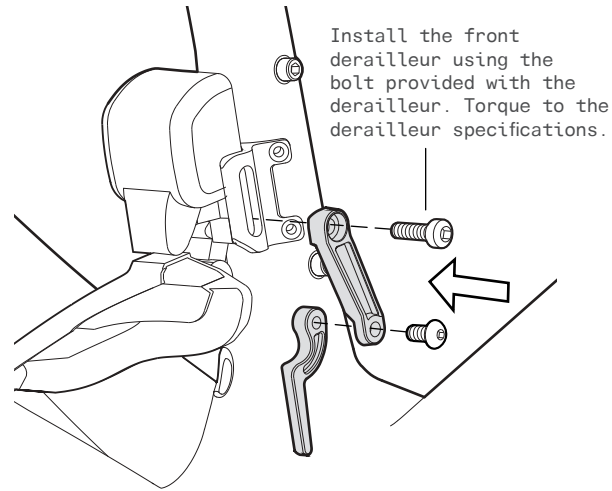

Install the front derailleur using the bolt provided with the derailleur. Torque to the derailleur specifications.

Install chain catcher when installing the front derailleur. Complete final adjustment with the chain in the small chainring and largest cassette cog. Tighten the connecting bolt to 4Nm.

NOTE: Installation of the chain catcher is recommended as it will prevent damage to the frame in the case that the chain is dropped inside the chainrings.

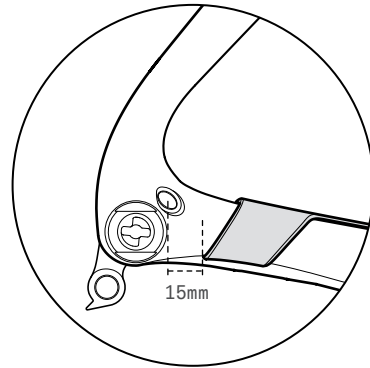
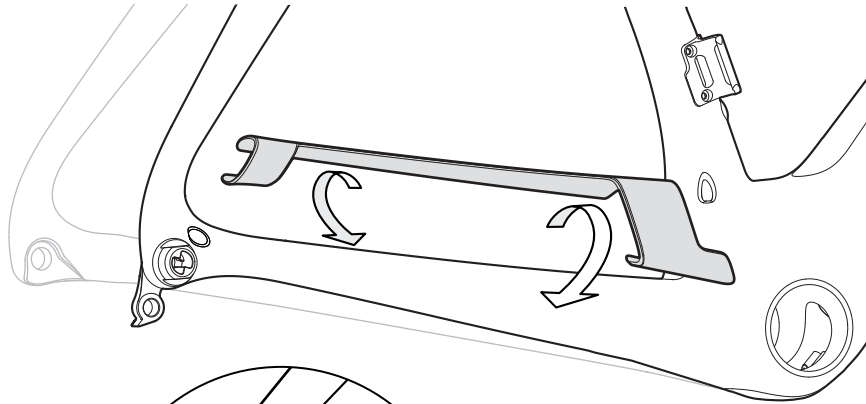

Clean the chainstay using isopropyl alcohol. Install the Chainstay Guard by removing adhesive backing, and fixing the guard to the frame. The bottom rearward edge should be approximately 15mm from the edge of the Rear Derailleur Hanger Fixing Nut.

TIRE CLEARANCE

Your Cervélo bicycle complies with the ISO 4210-2:4.10.2 standard for tire clearance. In order to comply with these safety standards and maintain your Limited Lifetime Warranty, a minimum of 4mm of clearance must remain between the tire and any frame element. Due to the growing complexity of tire and rim interfaces, Cervélo recommends identifying the available space before choosing a tire.

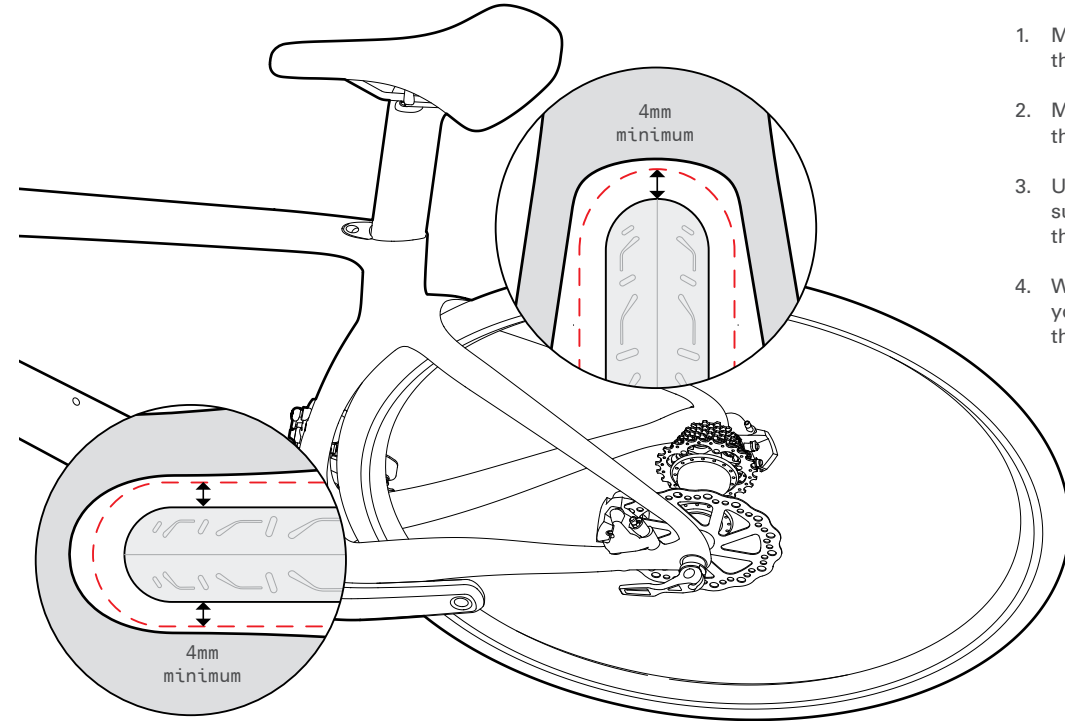

1. Measure the space between the chainstays at the bottom bracket junction.
2. Measure the space between the seatstays at the top of the tire.
3. Using the smallest of those two numbers, subtract 8mm (4mm per side) to determine the remaining space.
4. With the tire installed and fully inflated on your wheel, measure the tire width to ensure that it fits.

⚠ WARNING
Contact between the tire and the frame or fork may result in a loss of control while riding and potentially serious injury. Failure to follow these guidelines may result in damage to the frame not covered by Cervélo Limited Lifetime Warranty.

RAPID AXLE WHEEL INSTALLATION

⚠ WARNING
 To ensure rider safety, it is critical to install the Cervelo Rapid Axle correctly. Failure to do so may result in a crash, with potential for serious injury to the rider.

To secure the front wheel, install the greased axle, through the drive side drop out, through the wheel hub, aligning the T-End of the axle with the insert. Rotate the axle 90° clockwise until the T-End is stopped by the insert. If the lever is clamping too much/less adjust the preload nut until the lever is clamping securely.

⚠ WARNING
 The force required to close the lever should leave a clear imprint in the palm of your hand, or require wrapping your fingers around the fork leg for leverage while closing.

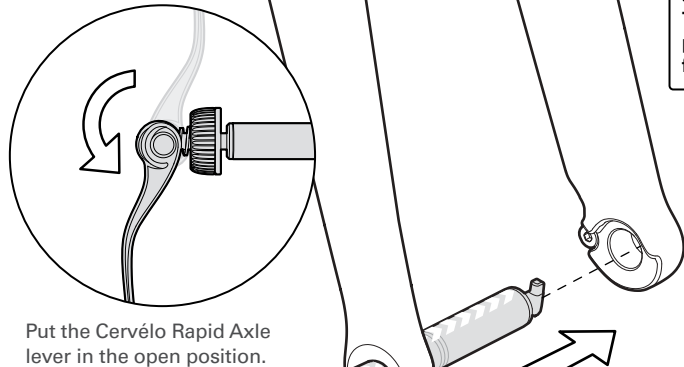

Put the Cervelo Rapid Axle lever in the open position.

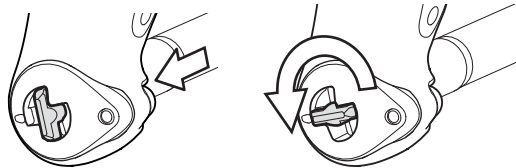

Insert axle

Rotate 90° to secure

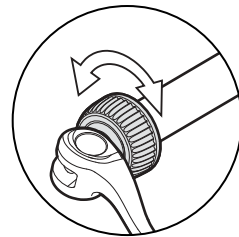

Use the preload nut to set the desired tension before closing.

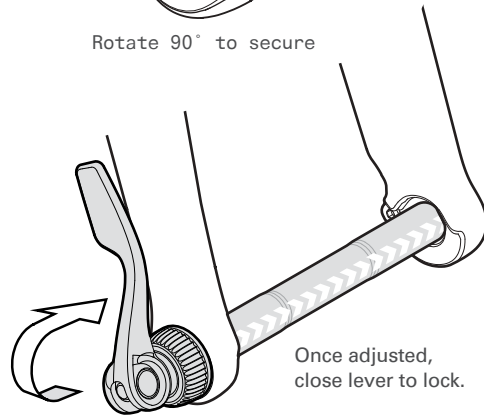

Once adjusted, close lever to lock.

When the axle lever is in the open position the arrows are visible. When the axle lever is in the closed position the Cervelo logo is visible.

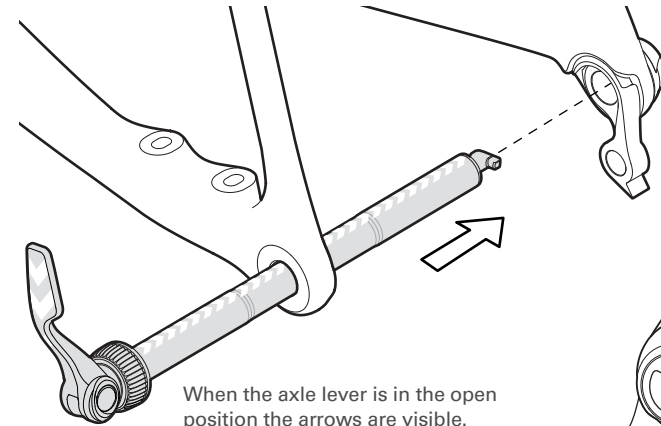

When the axle lever is in the open position the arrows are visible.

When the axle lever is in the closed position the Cervelo logo is visible.

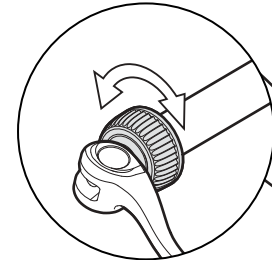

Use the preload nut to set the desired tension before closing.

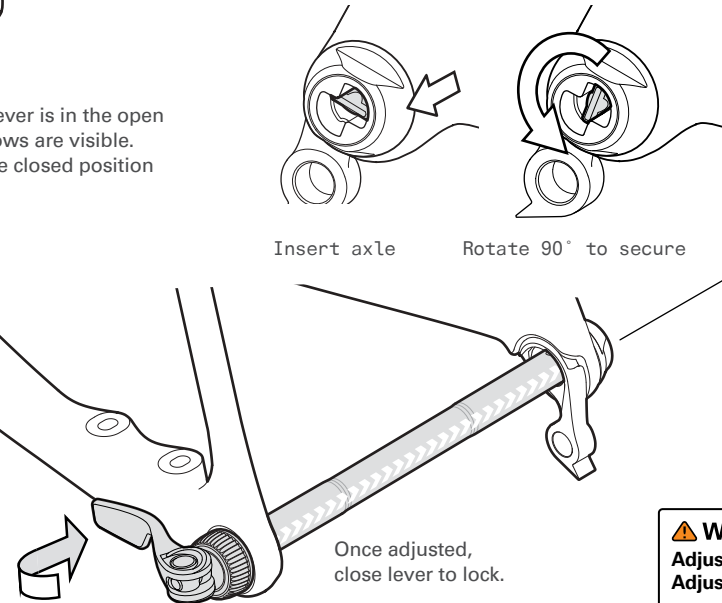

Insert axle

Rotate 90° to secure

Once adjusted, close lever to lock.

To secure the rear wheel, install the greased axle, through the non-drive side drop out, through the wheel hub, aligning the T-End of the axle with the derailleur hanger insert. Rotate the axle 90° clockwise until the T-End is stopped by the insert. If the lever is clamping too much/less adjust the preload nut until the lever is clamping securely.

⚠ WARNING
 The force required to close the lever should leave a clear imprint in the palm of your hand, or require wrapping your fingers around the chainstay for leverage while closing.

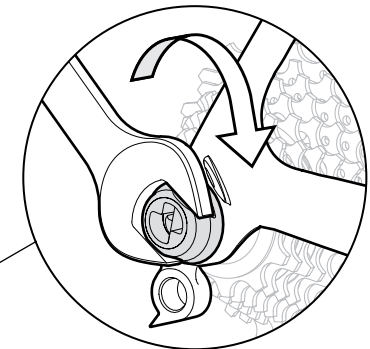

Perform final tightening on Rear Derailleur Hanger Fixing Nut using a 17mm wrench. This action is unique to initial assembly, and should not require adjustment afterwards.

⚠ WARNING
 Adjust brakes as per manufacturer's instructions. Adjust shifting as per manufacturer's instructions.

2019 S5 RETAILER ASSEMBLY MANUAL

www.cervelo.com

CER-S5-V2 2018-08-24

cervelo